

Roll No: _____

**MCA(Integrated)
(SEM II) THEORY EXAMINATION 2021-22
DIGITAL ELECTRONICS**

Time: 3 Hours

Total Marks: 70

Note: Attempt all Sections. If require any missing data; then choose suitably.

SECTION A

1. Attempt *all* questions in brief.

2*7 = 14

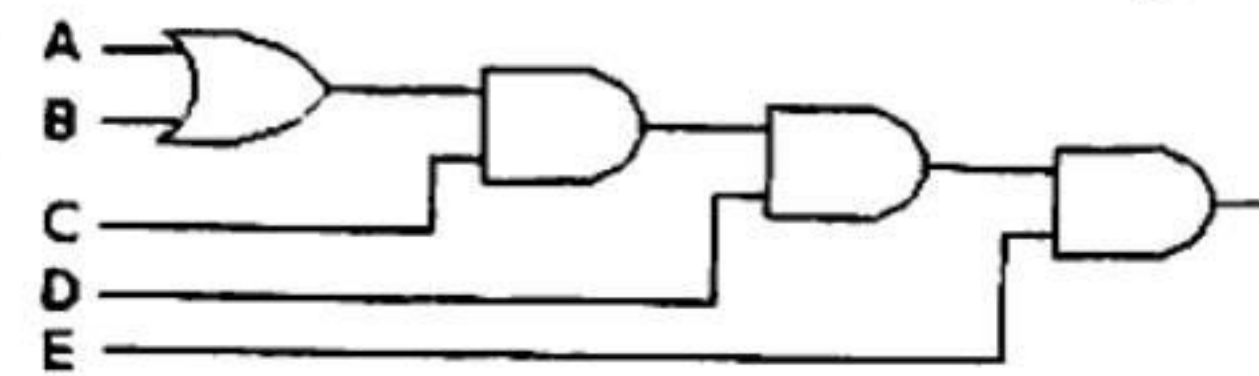
a.	convert a) (0110) _{BCD} to Excess-3. b) convert (10011010) _{XS-3} to BCD.
b.	Define the difference between canonical form and standard form.
c.	Define the following terms by giving suitable example (a) POS (b) SOP.
d.	Draw three variable K-map format.
e.	Derive the Boolean expression for the logic circuit shown below: 
f.	Differentiate between sequential circuit and combinational circuit.
g.	Define modulus of a counter? Write down the number of flip flops required for mod-5 counter?

SECTION B

2. Attempt any *three* of the following:

7*3 = 21

a.	Convert the following: i) (5C7) ₁₆ = (?) ₁₀ ii) (2598) ₁₀ = (?) ₁₆ ⁹²⁶ iii) (10110) ₂ = (?) ₁₀ = (?) ₁₆
b.	Explain the Basic theorems and Properties of Boolean algebra in detail.
c.	Simplify the Boolean function by means of Tabulation method: $F(A, B, C, D) = \sum m(9, 12, 13, 15) + \sum d(1, 4, 5, 7, 8, 11, 14)$
d.	Define Decimal Adder with truth table and logic diagram.
e.	Discuss the features of ripple counter in detail and design a 3-bit Ripple counter using a JK flip-flop along with its truth table.

SECTION C

3. Attempt any *one* part of the following:

7*1 = 7

a.	Define digital computer. Draw the functional parts of a digital computer and explain its block.
b.	If X= 1010100 and Y=1000011, Compute X-Y and Y - X using 1's complement and 2's complement.



Roll No:

MCA(Integrated)
(SEM II) THEORY EXAMINATION 2021-22
DIGITAL ELECTRONICS

4. Attempt any *one* part of the following:

7*1 = 7

- | | |
|----|--|
| a. | Realize the Boolean expression $Z = ABC + AD + CD'$ using NAND gates only. |
| b. | For the Boolean function
$F = xy'z + x'y'z + w'xy + wx'y + wxy$
a. Obtain the truth table of F.
b. Draw the logic diagram, using the original Boolean expression.
c. Use Boolean algebra to simplify the function to a minimum number of literals. |

5. Attempt any *one* part of the following:

7*1 = 7

- | | |
|----|---|
| a. | Minimise the following function in SOP minimal form using K-Maps: $F(A, B, C, D) = m(1, 2, 6, 7, 8, 13, 14, 15) + d(0, 3, 5, 12)$ |
| b. | Reduce the expression $f = \sum m(0, 1, 2, 3, 5, 7, 8, 9, 10, 12, 13)$ using K-maps and implement the real minimal expression using NAND logic. |

6. Attempt any *one* part of the following:

7*1 = 7

- | | |
|----|--|
| a. | Differentiate between full adder and half adder. Implement a full adder with two half adders and an OR gate. |
| b. | Realize the following function $F(A, B, C, D) = \sum m(1, 3, 4, 10, 11, 12, 13)$ using
a) 4 X 1 MUX
b) 8 X 1 MUX |

7. Attempt any *one* part of the following:

7*1 = 7

- | | |
|----|---|
| a. | Describe the working of Master-Slave JK Flip-Flop with Truth Table and Logic diagram. |
| b. | Discuss the different types of shift registers with their block diagram. |