

NARMADA

Test Booklet No. ↑

Test Booklet Code

45

ENGLISH

Do not open this Test Booklet until you are asked to do so.
 This Booklet contains 32 pages, including Rough Page.

Important Instructions:

1. The Answer Sheet is inside this Test Booklet. When you are directed to open the Test Booklet, take out the Answer Sheet and fill in the particulars on ORIGINAL Copy carefully with blue/black ball point pen only.
2. The test is of 3 hours duration and the Test Booklet contains 180 multiple-choice questions (four options with a single correct answer) from Physics, Chemistry and Biology (Botany and Zoology).
3. Wherever the symbols/constants are not mentioned, they are to be considered as per their standard meaning/value.
4. Each question carries 4 marks. For each correct response, the candidate will get 4 marks. For each incorrect response, one mark will be deducted from the total scores. The maximum marks are 720.
5. Use Blue/Black Ball Point Pen only for writing particulars on this page/marking responses on Answer Sheet.
6. Rough work is to be done in the space provided for this purpose in the Test Booklet only.
7. On completion of the test, the candidate must hand over the Answer Sheet (ORIGINAL and OFFICE Copy) to the Invigilator before leaving the Room/Hall. The candidates are allowed to take away this Test Booklet with them.
8. The CODE for this Booklet is "45". Make sure to enter this code in the OMR answer sheet.
9. The candidates should ensure that the Answer Sheet is not folded. Do not make any stray marks on the Answer Sheet. Do not write your Roll No. anywhere else except in the specified space in the Test Booklet/ Answer Sheet.
10. Use of white fluid for correction is NOT permissible on the Answer Sheet.
11. Each candidate must show on-demand his/her Admit Card to the Invigilator.
12. No candidate, without special permission of the centre Superintendent or Invigilator, would leave his/her seat.
13. The candidates should not leave the Examination Hall without handing over their Answer Sheet to the Invigilator on duty and sign (with time) the Attendance Sheet twice. Cases, where a candidate has not signed the Attendance Sheet second time, will be deemed not to have handed over the Answer Sheet and dealt with as an Unfair Means case.
14. Use of Electronic/Manual Calculator is prohibited.
15. The candidates are governed by all Rules and Regulations of the examination with regard to the conduct in the Examination Room/Hall. All cases of unfair means will be dealt with as per the Rules and Regulations of this examination along with Public Examinations (Prevention of unfair means act 2024).
16. No part of the Test Booklet and Answer Sheet shall be detached under any circumstances.
17. The candidates will write the Correct Test Booklet Code as given in the Test Booklet/Answer Sheet in the Attendance Sheet.
18. If a candidate marks more than one answers for a question in the OMR Sheet, it will be treated as incorrect and negative marking will be applicable.

Name of the Candidate (in Capitals) :

Roll Number : in figures

: in words

Centre of Examination (in Capitals) :

Candidate's Signature : Invigilator's Signature :

Facsimile signature stamp of Centre Superintendent :

1. Consider a water tank shown in the figure.

It has one wall at $x = L$ and can be taken to be very wide in the z direction. When filled with a liquid of surface tension S and density ρ , the liquid surface makes angle θ ($\theta \ll 1$) with the x -axis at $x=L$. If $y(x)$ is the height of the surface then the equation for $y(x)$ is:

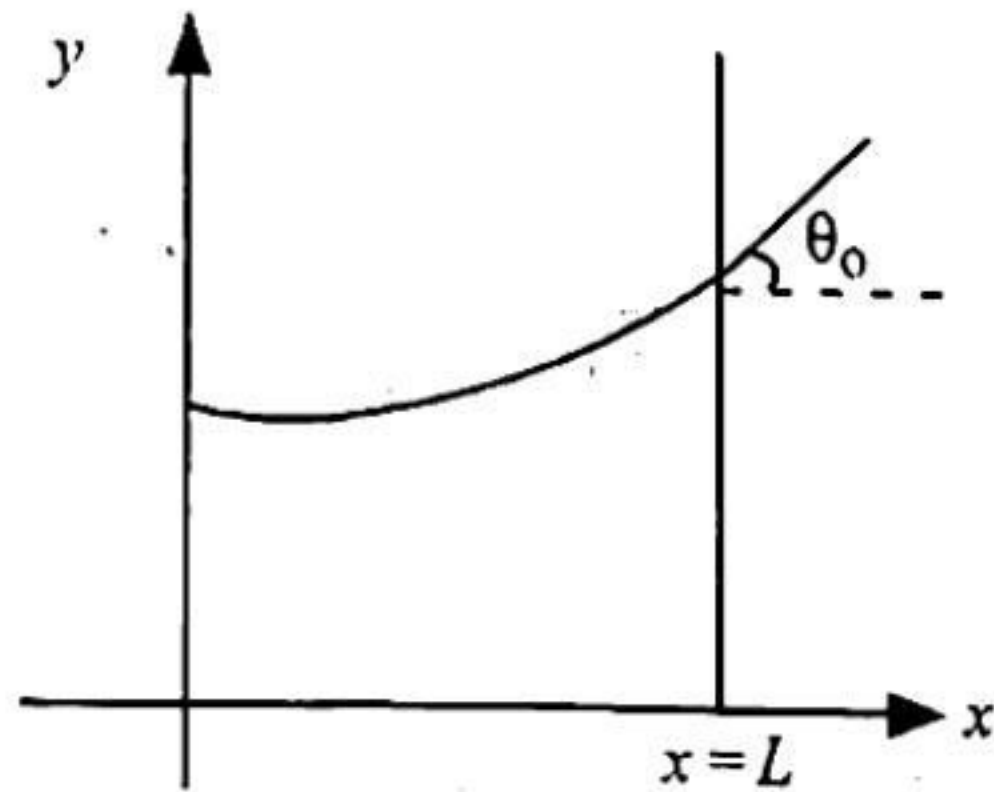

(take $\theta(x) = \sin \theta(x) = \tan \theta(x) = \frac{dy}{dx}$, g is the acceleration due to gravity)

(1) $\frac{d^2y}{dx^2} = \frac{\rho g}{S} x$

(2) $\frac{d^2y}{dx^2} = \frac{\rho g}{S} y$

(3) $\frac{d^2y}{dx^2} = \sqrt{\frac{\rho g}{S}}$

(4) $\frac{dy}{dx} = \sqrt{\frac{\rho g}{S}} x$

2. A microscope has an objective of focal length 2 cm, eyepiece of focal length 4 cm and tube length of 40 cm. If the distance of distinct vision of eye is 25 cm; the magnification in the microscope is

(1) 100

(2) 125

(3) 150

(4) 250

3. An electron (mass 9×10^{-31} kg and charge 1.6×10^{-19} C) moving with speed $c/100$ ($c =$ speed of light) is injected into a magnetic field \vec{B} of magnitude 9×10^{-4} T perpendicular to its direction of motion. We wish to apply a uniform electric field \vec{E} together with the magnetic field so that the electron does not deflect from its path. Then (speed of light $c = 3 \times 10^8$ ms $^{-1}$)

- (1) \vec{E} is perpendicular to \vec{B} and its magnitude is 27×10^4 V m $^{-1}$
- (2) \vec{E} is perpendicular to \vec{B} and its magnitude is 27×10^2 V m $^{-1}$
- (3) \vec{E} is parallel to \vec{B} and its magnitude is 27×10^2 V m $^{-1}$
- (4) \vec{E} is parallel to \vec{B} and its magnitude is 27×10^4 V m $^{-1}$

4. There are two inclined surfaces of equal length (L) and same angle of inclination 45° with the horizontal. One of them is rough and the other is perfectly smooth. A given body takes 2 times as much time to slide down on rough surface than on the smooth surface. The coefficient of kinetic friction (μ_k) between the object and the rough surface close to

- (1) 0.25
- (2) 0.40
- (3) 0.5
- (4) 0.75

5. The kinetic energies of two similar cars A and B are 100 J and 225 J respectively. On applying breaks, car A stops after 1000 m and car B stops after 1500 m. If F_A and F_B are the forces applied by the breaks on cars A and B, respectively, then the ratio F_A/F_B is

- (1) $\frac{3}{2}$
- (2) $\frac{2}{3}$
- (3) $\frac{1}{3}$
- (4) $\frac{1}{2}$

6. The current passing through the battery in the given circuit, is:

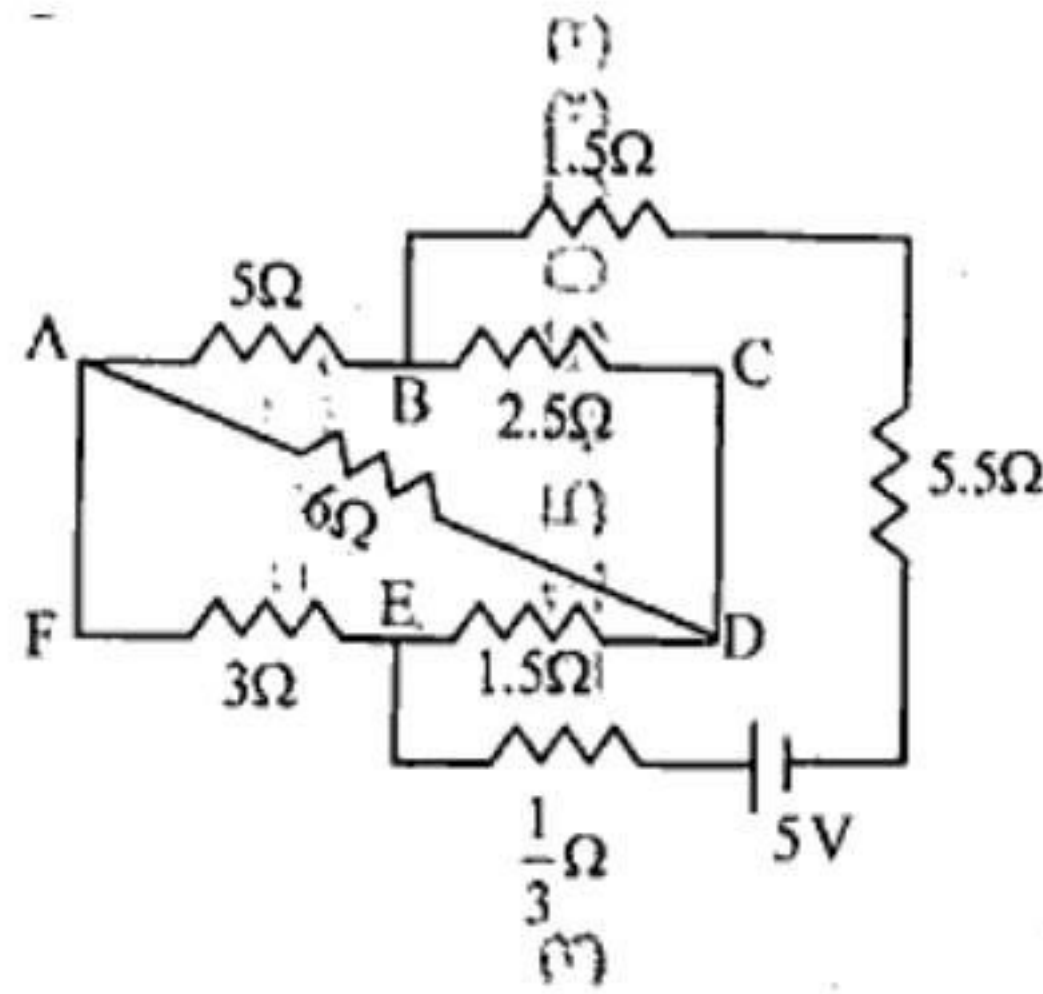

- (1) 2.0 A
- (2) 0.5 A
- (3) 2.5 A
- (4) 1.5 A

7. A bob of heavy mass m is suspended by a light string of length l . The bob is given a horizontal velocity v_0 as shown in figure. If the string gets slack at some point P making an angle θ from the horizontal, the ratio of the speed v of the bob at point P to its initial speed v_0 is:

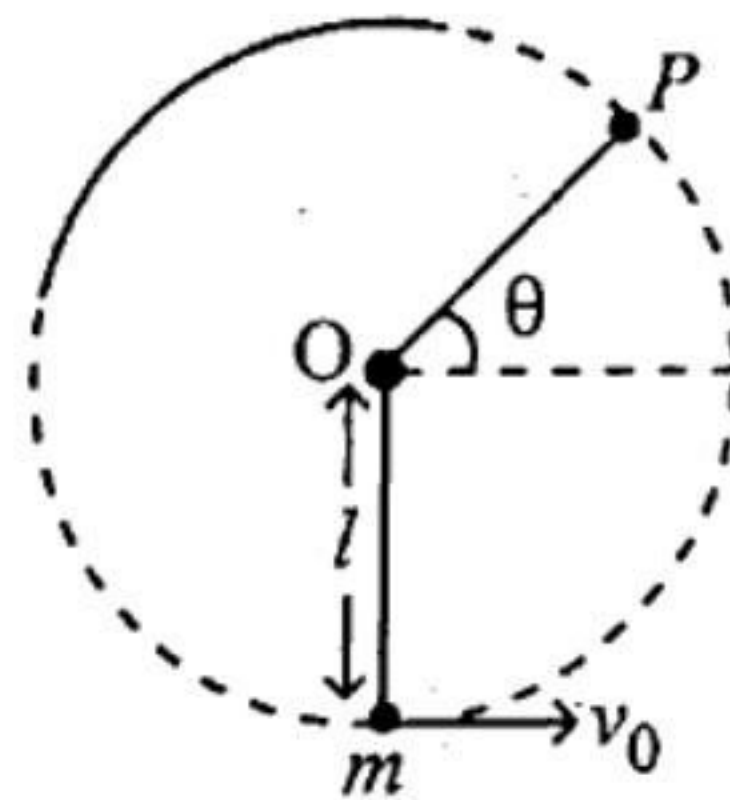

- (1) $(\sin \theta)^{1/2}$
- (2) $\left(\frac{1}{2+3 \sin \theta}\right)^{1/2}$
- (3) $\left(\frac{\cos \theta}{2+3 \sin \theta}\right)^{1/2}$
- (4) $\left(\frac{\sin \theta}{2+3 \sin \theta}\right)^{1/2}$

8. The output (Y) of the given logic implementation is similar the output of an/a _____ gate

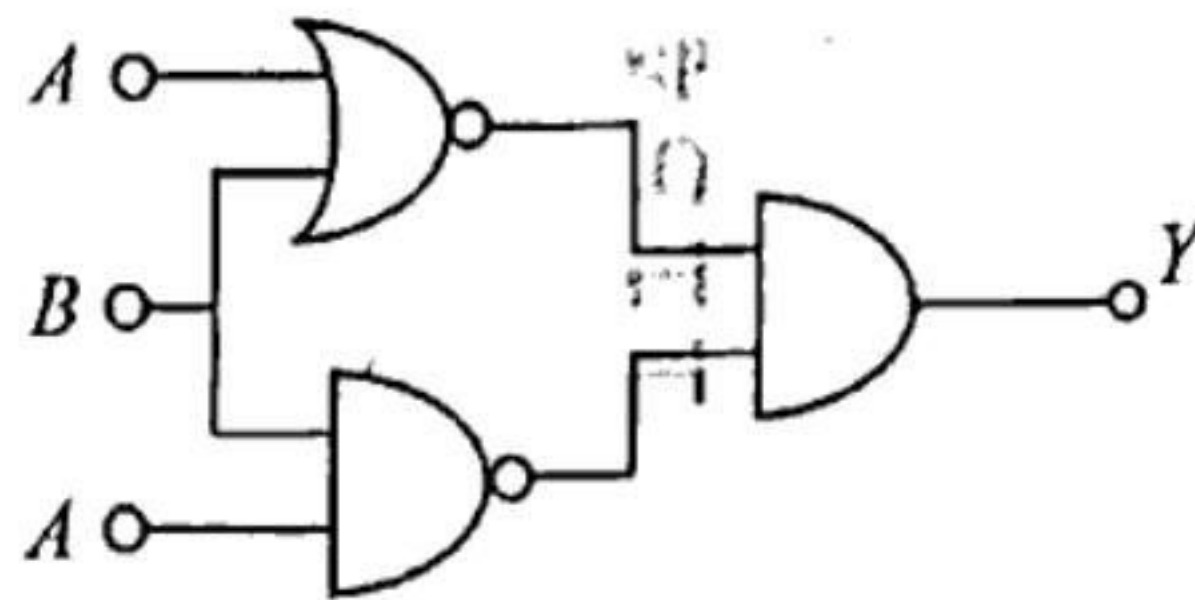

- (1) AND
- (2) NAND
- (3) OR
- (4) NOR

9. The electric field in a plane electromagnetic wave is given by

$$E_z = 60 \cos(5x + 1.5 \times 10^9 t) \text{ V/m.}$$

Then expression for the corresponding magnetic field is (here subscripts denote the direction of the field):

- (1) $B_y = 2 \times 10^{-7} \cos(5x + 1.5 \times 10^9 t) \text{ T}$
- (2) $B_x = 2 \times 10^{-7} \cos(5x + 1.5 \times 10^9 t) \text{ T}$
- (3) $B_z = 60 \cos(5x + 1.5 \times 10^9 t) \text{ T}$
- (4) $B_y = 60 \sin(5x + 1.5 \times 10^9 t) \text{ T}$

10. A ball of mass 0.5 kg is dropped from a height of 40 m. The ball hits the ground and rises to a height of 10 m. The impulse imparted to the ball during its collision with the ground is (Take $g = 9.8 \text{ m/s}^2$)

- (1) 21 NS
- (2) 7 NS
- (3) 0
- (4) 84 NS

11. AB is a part of an electrical circuit (see figure). The potential difference " $V_A - V_B$ ", at the instant when current $i = 2$ A and is increasing at a rate of 1 amp/second is:

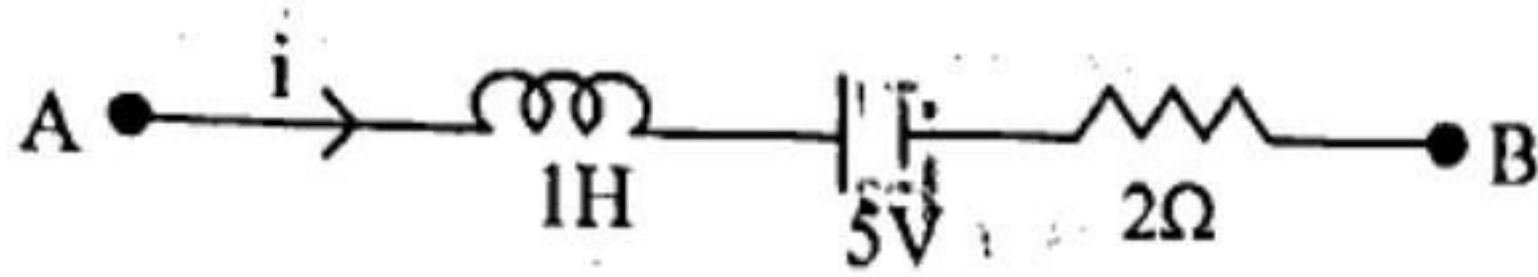

- (1) 5 volt
- (2) 6 volt
- (3) 9 volt
- (4) 10 volt

12. A 2 amp current is flowing through two different small circular copper coils having radii ratio 1:2. The ratio of their respective magnetic moments will be

- (1) 1:4
- (2) 1:2
- (3) 2:1
- (4) 4:1

13. In a certain camera combination of four similar thin convex lenses arranged axially in contact. Then the power of the combination and the total magnification in comparison to the power (p) and magnification (m) for each lens will be, respectively-

- (1) $4p$ and $4m$
- (2) p^4 and $4m$
- (3) $4p$ and m^4
- (4) p^4 and m^4

14. An oxygen cylinder of volume 30 litre has 18.20 moles of oxygen. After some oxygen is withdrawn from the cylinder, its gauge pressure drops to 1.1 atmospheric pressure at temperature 27°C . The mass of the oxygen withdrawn from the cylinder is nearly equal to:

[Given, $R = \frac{100}{12} \text{ J mol}^{-1} \text{ K}^{-1}$, and

molecular mass of O_2 -32,

1 atm pressure $1.01 \times 10^5 \text{ N/m}$]

(1) 0.125 kg

(2) 0.144 kg

(3) 0.116 kg

(4) 0.156 kg

15. In some appropriate units, time (t) and position (x) relation of a moving particle is given by $t=x^2+x$. The acceleration of the particle is

(1) $-\frac{2}{(x+2)^3}$

(2) $-\frac{2}{(2x+1)^3}$

(3) $+\frac{2}{(x+1)^3}$

(4) $+\frac{2}{(2x+1)}$

16. To an ac power supply of 220 V at 50 Hz, a resistor of 20Ω , a capacitor of reactance 25Ω and an inductor of reactance 45Ω are connected in series. The corresponding current in the circuit and the phase angle between the current and the voltage is, respectively-

(1) 7.8 A and 30°

(2) 7.8 A and 45°

(3) 15.6 A and 30°

(4) 15.6 A and 45°

17. The Sun rotates around its centre once in 27 days. What will be the period of revolution if the Sun were to expand to twice its present radius without any external influence? Assume the Sun to be a sphere of uniform density.

(1) 100 days

- (2) 105 days
- (3) 115 days
- (4) 108 days

18. A model for quantized motion of an electron in a uniform magnetic field B states that the flux passing through the orbit of the electron is $n(h/e)$ where n is an integer, h is Planck's constant and e is the magnitude of electron's charge. According to the model, the magnetic moment of an electron in its lowest energy state will be (m is the mass of the electron) <https://www.validcollege.com>

- (1) $\frac{he}{\pi m}$
- (2) $\frac{he}{2\pi m}$
- (3) $\frac{heB}{\pi m}$
- (4) $\frac{heB}{2\pi m}$

19. Three identical heat conducting rods are connected in series as shown in the figure. The rods on the sides have thermal conductivity $2K$ while that in the middle has thermal conductivity K . The left end of the combination is maintained at temperature $3T$ and the right end at T . The rods are thermally insulated from outside. In steady state, temperature at the left junction is T_1 and that at the right junction is T_2 . The ratio T_1/T_2 is

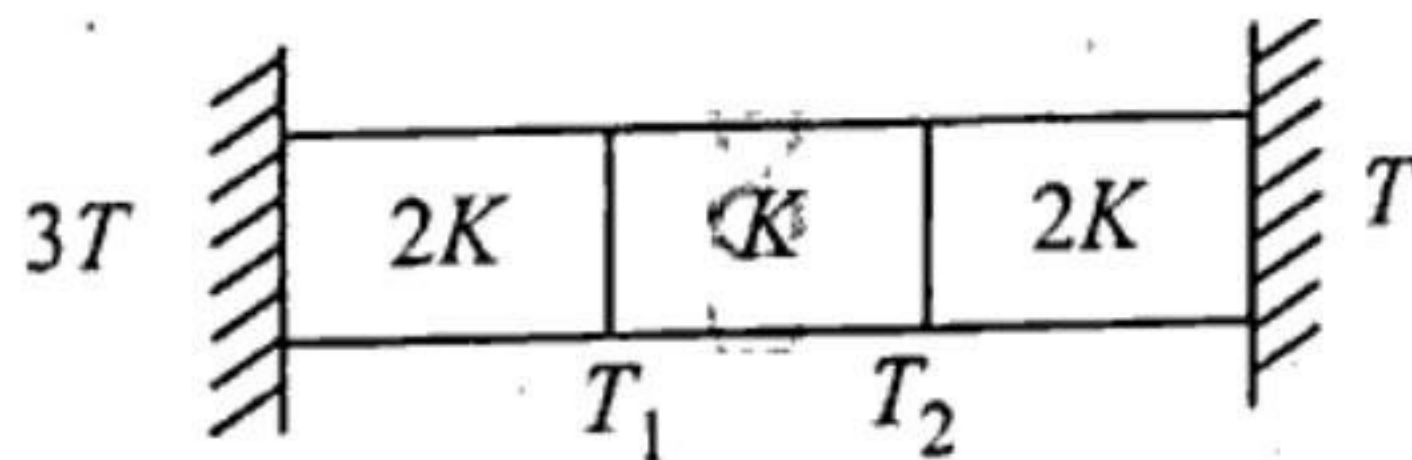

- (1) $\frac{3}{2}$
- (2) $\frac{4}{3}$
- (3) $\frac{5}{3}$
- (4) $\frac{5}{4}$

20. The plates of a parallel plate capacitor are separated by d . Two slabs of different dielectric constant K_1 and K_2 with thickness $\frac{3}{8}d$ and $\frac{d}{2}$ respectively are inserted in the capacitor. Due to this, the capacitance becomes two times larger than when there is nothing between the plates.

If $K_1 = 1.25 K_2$ the value of K_1 is:

- (1) 2.66
- (2) 2.33
- (3) 1.60
- (4) 1.33

21. Two cities X and Y are connected by a regular bus service with a bus leaving in either direction every T min. A girl is driving scooter with a speed of 60 km/h in the direction X to Y notices that a bus goes past her every 30 minutes in the direction of her motion, and every 10 minutes in the opposite direction. Choose the correct option for the period T of the bus service and the speed (assumed constant) of the buses.

- (1) 9 min, 40 km/h
- (2) 25 min, 100 km/h
- (3) 10 min, 90 km/h
- (4) 15 min, 120 km/h

22. A uniform rod of mass 20 kg and length 5 m leans against a smooth vertical wall making an angle of 60° with it. The other end rests on a rough horizontal floor. The friction force that the floor exerts on the rod is (take $g = 10 \text{ m/s}^2$)

- (1) 100 N
- (2) $100\sqrt{3}$ N
- (3) 200 N
- (4) $200\sqrt{3}$ N

23. In an oscillating spring mass system, a spring is connected to a box filled with sand. As the box oscillates, sand leaks slowly out of the box vertically so that the average frequency $\omega(t)$ and average amplitude $A(t)$ of the system change with time t . Which one of the following options schematically depicts these changes correctly?

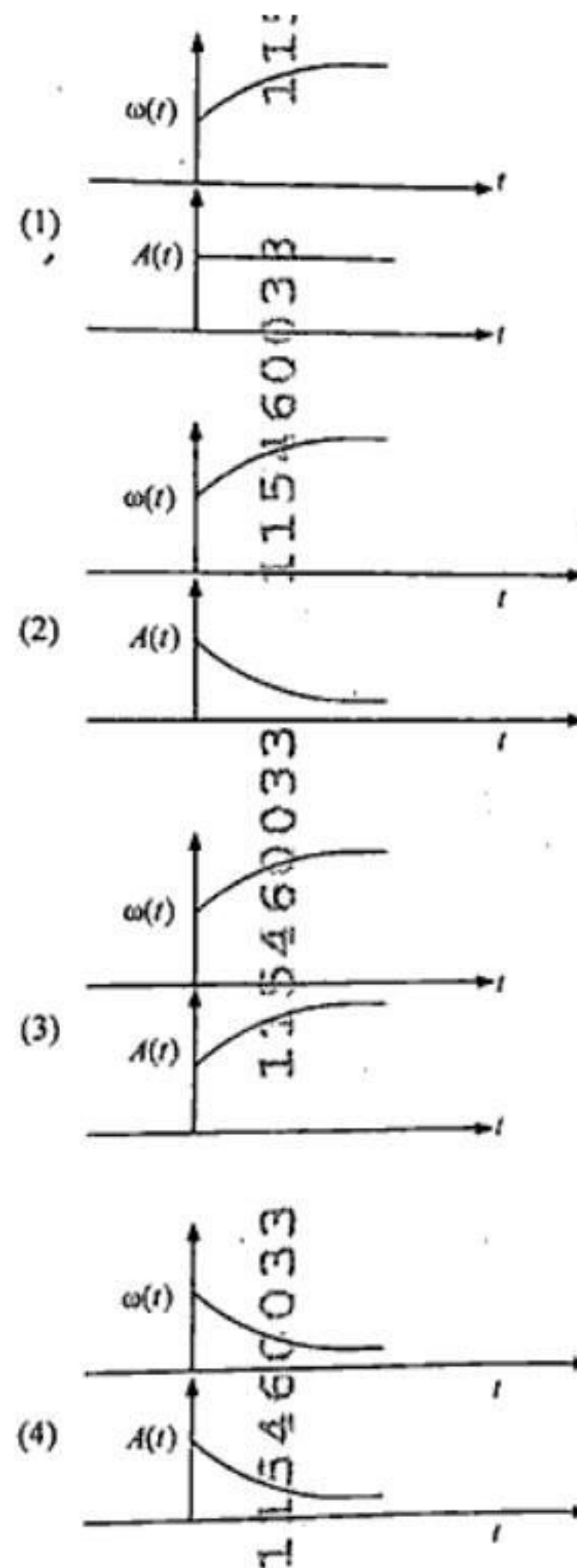

24. A balloon is made of a material of surface tension S and its inflation outlet (from where gas is filled in it has small area A). It is filled with a gas of density ρ and takes a spherical shape of radius R . When the gas is allowed to flow freely out of it, its radius r changes from R to 0 (zero) in time T . If the speed $v(r)$ of gas coming out of the balloon depends on r as r^a and $T \propto S^\alpha A^\beta \rho^\gamma S^\delta$ then

(1) $a = \frac{1}{2}, \alpha = \frac{1}{2}, \beta = -1, \gamma = +1, \delta = \frac{3}{2}$

(2) $a = -\frac{1}{2}, \alpha = -\frac{1}{2}, \beta = -1, \gamma = -\frac{1}{2}, \delta = \frac{5}{2}$

(3) $a = -\frac{1}{2}, \alpha = -\frac{1}{2}, \beta = -1, \gamma = \frac{1}{2}, \delta = \frac{7}{2}$

(4) $a = \frac{1}{2}, \alpha = \frac{1}{2}, \beta = -\frac{1}{2}, \gamma = \frac{1}{2}, \delta = \frac{7}{2}$

25. Consider the diameter of a spherical object being measured with the help of a Vernier callipers. Suppose its 10 Vernier Scale Divisions (V.S.D.) are equal to its 9 Main Scale Divisions (M.S.D.). The least division, in the M.S. is 0.1 cm, and the zero of V.S. is at $x=0.1$ cm when the jaws of Vernier calipers are closed.

If the main scale, reading for the diameter is $M = 5$ cm and the number of coinciding vernier division is 8, the measured diameter after zero error correction, is

- (1) 5.18 cm
- (2) 5.08 cm
- (3) 4.98 cm
- (4) 5.00 cm

26. A parallel plate capacitor made of circular, plates is being charged such that the surface charge density on its plates is increasing at a constant rate with time. The magnetic field arising due to displacement current is:

- (1) zero at all places
- (2) constant between the plates and zero outside the plates
- (3) non-zero everywhere with maximum at the imaginary cylindrical surface connecting peripheries of the plates
- (4) zero between the plates and non-zero outside

27. An unpolarized light beam travelling in air is incident on a medium of refractive index 1.73 at Brewster's angle, Then-

- (1) reflected light is completely polarized and the angle of reflection is close to 60°
- (2) reflected light is partially polarized and the angle of reflection is close to 30°
- (3) both reflected and transmitted light are perfectly-polarized with angles of reflection and refraction close to 60° and 30° , respectively.
- (4) transmitted light is completely polarized with angle of refraction close to 30°

28. Two identical charged conducting spheres A and B have their centres separated by a certain distance. Charge on each sphere is q and the force of repulsion

between them is F . A third identical uncharged conducting sphere is brought in contact with sphere A first and then with B and finally removed from both. New force of repulsion between spheres A and B (Radii of A and B are negligible compared to the distance of separation so that for calculating force between them they can be considered as point, charges) is best given as :

(1) $\frac{3F}{5}$

(2) $\frac{2F}{3}$

(3) $\frac{F}{2}$

(4) $\frac{3F}{8}$

29. A container has two chambers of volumes $V_1 = 2$ litres and $V_2 = 3$ litres separated by a partition made of a thermal insulator. The chambers contains $n_1 = 5$ and $n_2 = 4$ moles of ideal gas at pressures $p_1 = 1$ atm and $P_2 = 2$ atm, respectively. When the partition is removed, the mixture attains an equilibrium pressure of:

(1) 1.3 atm

(2) 1.6 atm

(3) 1.4 atm

(4) 1.8 atm

30. A particle of mass m is moving around the origin with a constant force F pulling it towards the origin. If Bohr model is used to describe its motion, the radius r of the n th orbit and the particle's speed v in the orbit depend on n as

(1) $r \propto n^{1/3}, v \propto n^{1/3}$

(2) $r \propto n^{1/3}, v \propto n^{2/3}$

(3) $r \propto n^{2/3}, v \propto n^{1/3}$

(4) $r \propto n^{4/3}, v \propto n^{-1/3}$

31. The radius of Martian orbit around the Sun is about 4 times the radius of the orbit of Mercury. The Martian year is 687 Earth days. Then which of the following is the length of 1 year on Mercury ?

- (1) 88 earth days
- (2) 225 earth days
- (3) 172 earth days
- (4) 124 earth days

32. A body weighs 48 N on the surface of the earth. The gravitational force experienced by the body due to the earth at a height equal to one-third the radius of the earth from its surface is :

- (1) 16 N
- (2) 27 N
- (3) 32 N
- (4) 36 N

33. A wire of resistance R is cut into 8 equal pieces. From these pieces two equivalent resistances are made by adding four of these in parallel. Then these two sets are added in series. The net effective resistance of the combination is :

- (1) $\frac{R}{64}$
- (2) $\frac{R}{32}$
- (3) $\frac{R}{16}$
- (4) $\frac{R}{8}$

34. De-Broglie wavelength of an electron orbiting in the n=2 state of hydrogen atom is close to (Given Bohr radius = 0.052 nm)

- (1) 0.067 nm
- (2) 0.67 nm
- (3) 1.67 nm
- (4) 2.67 nm

35. An electric dipole with dipole moment $5 \times 10^{-6} \text{ C m}$ is placed in a uniform electric field of magnitude $4 \times 10^5 \text{ NC}$. The dipole is then rotated through an angle of 60° with respect to the electric field. The change in the potential energy of the dipole is :

- (1) 0.8 J
- (2) 1.0 J
- (3) 1.2 J
- (4) 1.5 J

36. A constant voltage of 50 V is maintained between the points A and B of the circuit shown in the figure. The current through the branch CD of the circuit is :

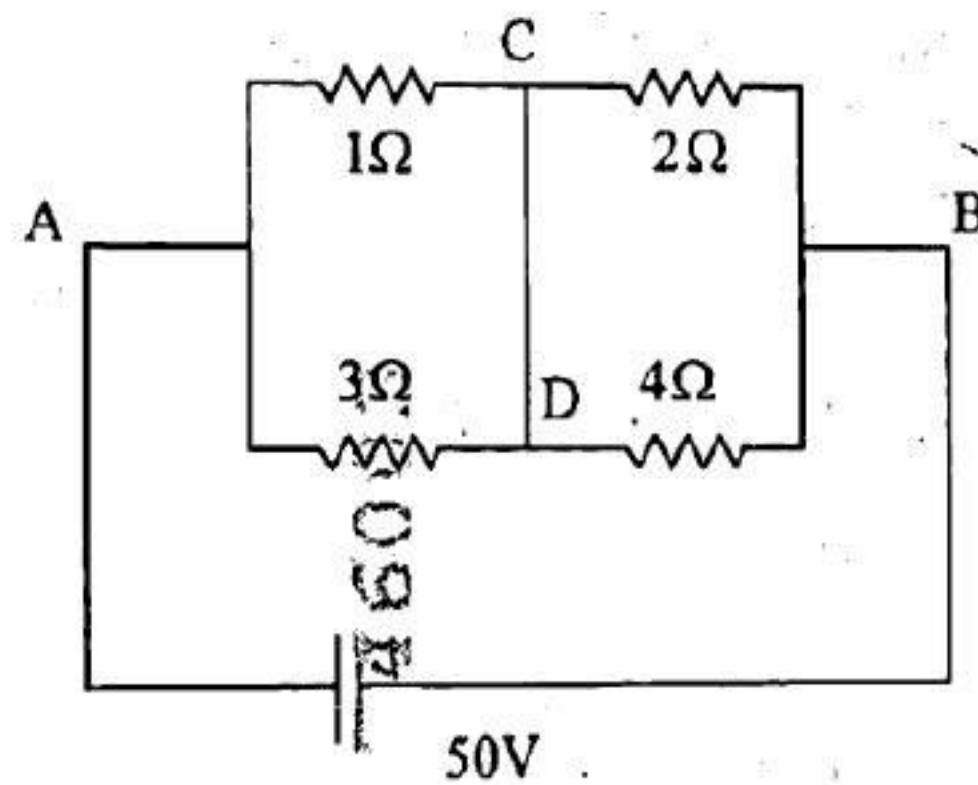

- (1) 1.5 A
- (2) 2.0 A
- (3) 2.5 A
- (4) 3.0 A

37. A photon and an electron (mass m) have the same energy E . The ratio (λ_e / λ_p) of their de Broglie wavelengths is (c is the speed of light)

- (1) $\sqrt{E/2m}$
- (2) $c \sqrt{2mE}$
- (3) $c \sqrt{\frac{2m}{E}}$
- (4) $\frac{1}{c} \sqrt{\frac{E}{2m}}$

38. Which of the following options represent the variation of the photoelectric current with frequency of light shown on the x-axis?

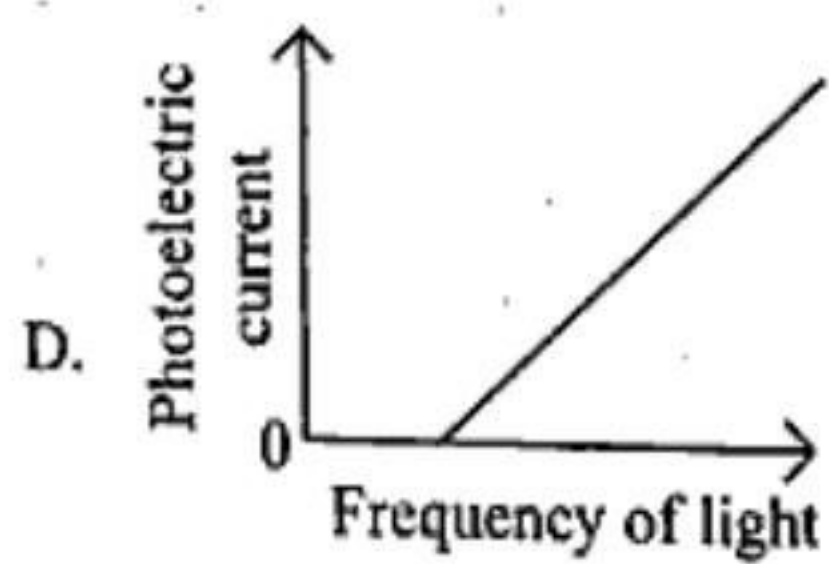
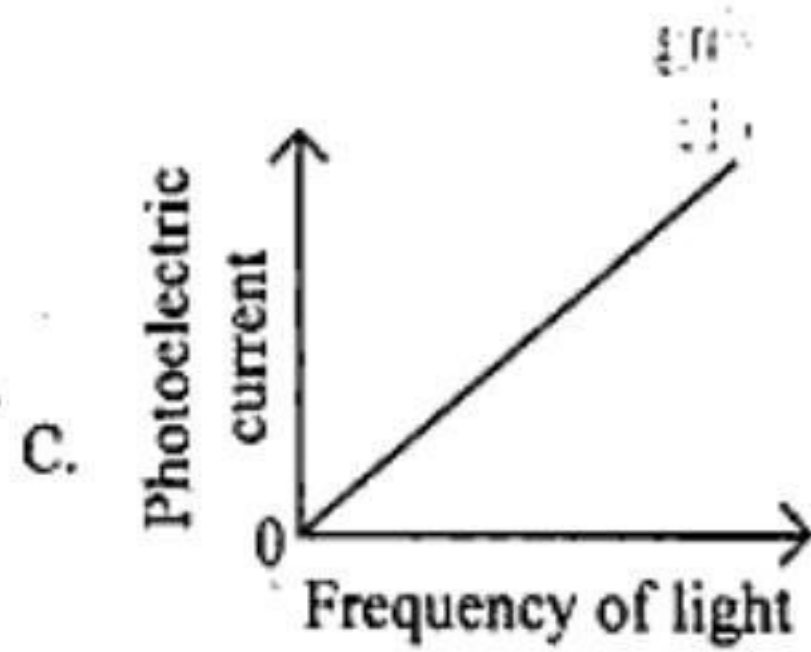
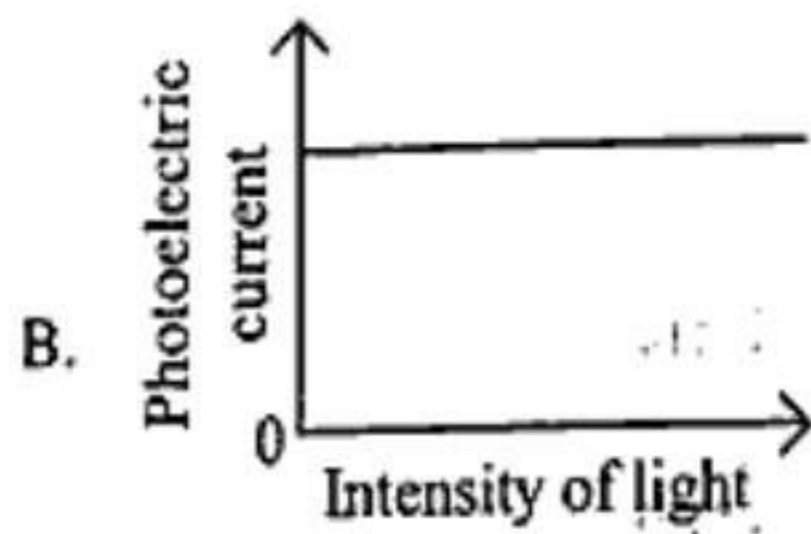
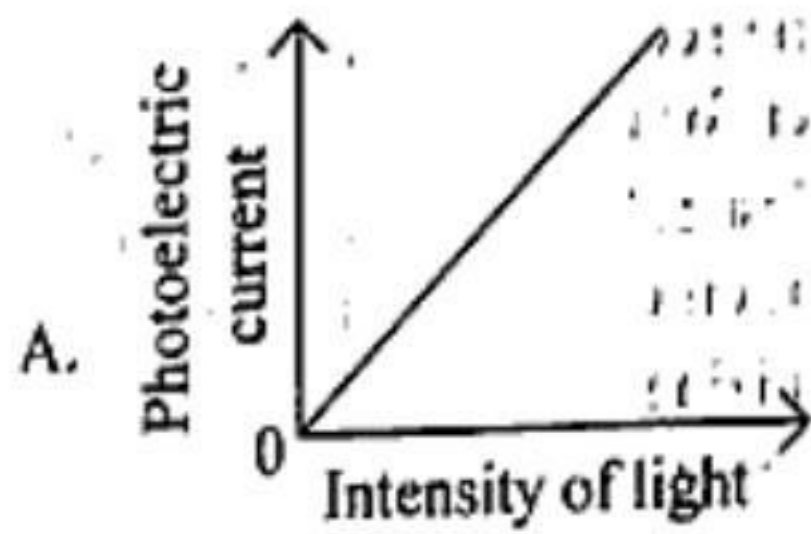

- (1) A only
- (2) A and C
- (3) A and D
- (4) B and D

39. A sphere of radius $2R$ is cut from a larger solid sphere of radius $5R$ as shown in the figure. The ratio of the moment of inertia of the smaller sphere to that of the rest part of the sphere about the Y-axis is :

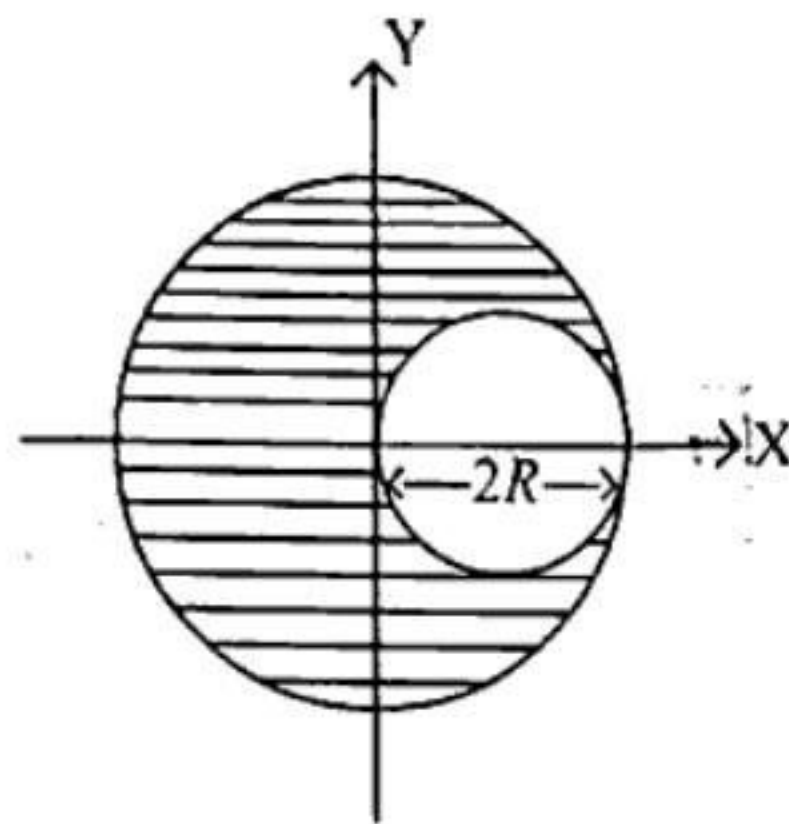

- (1) $\frac{7}{8}$
- (2) $\frac{7}{40}$
- (3) $\frac{7}{57}$
- (4) $\frac{7}{64}$

40. A full wave rectifier circuit with diodes (D_1) and (D_2) is shown in the figure. If input supply voltage $V_{in} = 220 \sin(100\pi t)$ volt, then at $t = 15$ msec

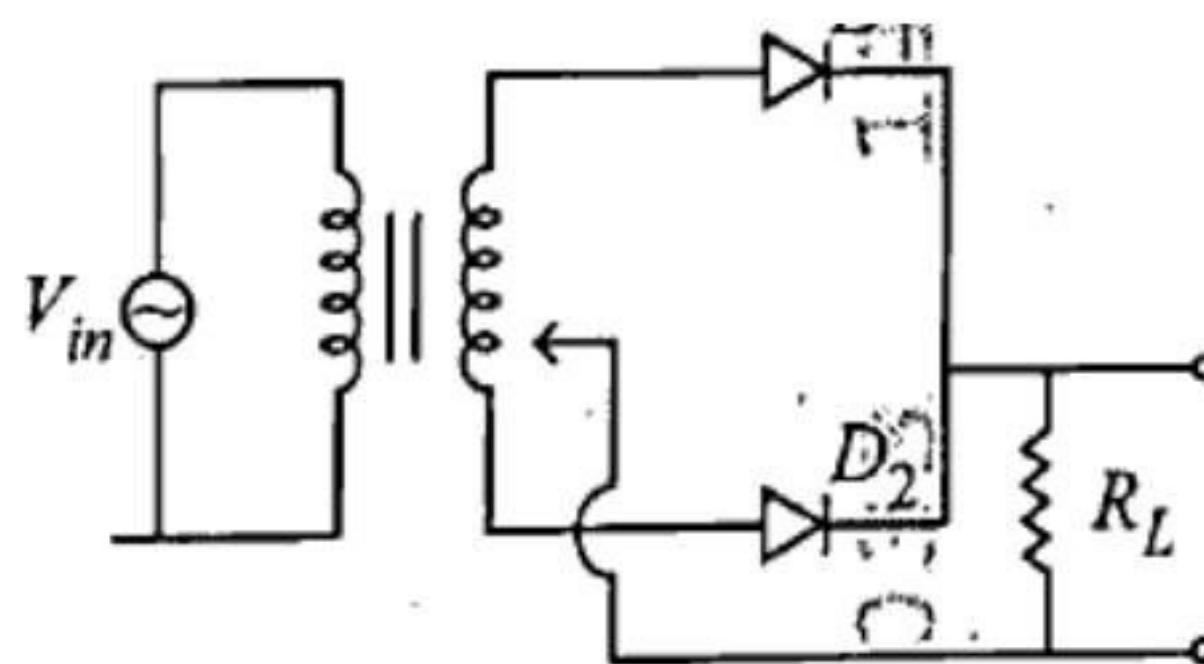

- (1) D_1 is forward biased, D_2 is reverse biased
- (2) D_1 is reverse biased, D_2 is forward biased
- (3) D_1 and D_2 both are forward biased
- (4) D_1 and D_2 both are reverse biased

41. Two gases A and B are filled at the same pressure in separate cylinders with movable pistons of radius r_A and r_B , respectively. On supplying an equal amount of heat to both the systems reversibly under constant pressure, the pistons of gas A and B are displaced by 16 cm and 9 cm, respectively. If the change in their internal energy is the same, then the ratio r_A / r_B is equal to

(1) $\frac{4}{3}$

(2) $\frac{3}{4}$

(3) $\frac{2}{\sqrt{3}}$

(4) $\frac{\sqrt{3}}{2}$

42. A physical quantity P is related to four observations a, b, c and d as follows:

$$P = a^3 b^2 / c \sqrt{d}$$

The percentage errors of measurement in a, b, c and d are 1%, 3%, 2% and 4% respectively. The percentage error in the quantity P is

(1) 10%

(2) 2%

(3) 13%

(4) 15%

43. The intensity of transmitted light when a polaroid sheet, placed between two crossed polaroids at 22.5° from the polarization axis of one of the polaroid, (I_0 is the intensity of polaroid light passing through the first polaroid):

(1) $\frac{I_0}{2}$

(2) $\frac{I_0}{4}$

(3) $\frac{I_0}{8}$

(4) $\frac{I_0}{16}$

44. Two identical point masses P and Q, suspended from two separate massless springs of spring constants k_1 and k_2 respectively, oscillate vertically. If their maximum speeds are the same, the ratio (A_Q / A_P) of the amplitude A_Q of mass Q to the amplitude A_P of mass P is:

(1) $\frac{k_2}{k_1}$

(2) $\frac{k_1}{k_2}$

(3) $\sqrt{\frac{k_2}{k_1}}$

(4) $\sqrt{\frac{k_1}{k_2}}$

45. A pipe open at both ends has a fundamental frequency f in air. The pipe is now dipped vertically in a water drum to half of its length. The fundamental frequency of the air column is now equal to :

(1) $\frac{f}{2}$

(2) f

(3) $\frac{3f}{2}$

(4) $2f$

46. The ratio of the wavelengths of the light absorbed by a Hydrogen atom when it undergoes $n=2 \rightarrow n=3$ and $n=4 \rightarrow n=6$ transitions, is

(1) $\frac{1}{36}$

(2) $\frac{1}{16}$

(3) $\frac{1}{9}$

(4) $\frac{1}{4}$

47. Which of the following statements are true?

A. Unlike Ga that has a very high melting point, Cs has a very low melting point.

- B. On Pauling scale, the electronegativity values of N and Cl are not the same.
- C. Ar, K^+ , Cl^- , Ca^{2+} , and S^{2-} are all isoelectronic species.
- D. The correct order of the first ionization enthalpies of Na, Mg, Al, and Si is $Si > Al > Mg > Na$.
- E. The atomic radius of Cs is greater than that of Li and Rb.

Choose the correct answer from the options given below :

- (1) A, B, and E only
- (2) C and E only
- (3) C and D only
- (4) A, C, and E only

48. Match List I with List II

List I (Ion)	List II (Group Number in Cation Analysis)
A. Co^{2+}	I. Group-I
B. Mg^{2+}	II. Group-III
C. Pb^{2+}	III. Group-IV
D. Al^{3+}	IV. Group-VI

Choose the correct answer from the options given below :

- (1) A-III, B-IV, C-II, D-I
- (2) A-III, B-IV, C-I, D-II
- (3) A-III, B-II, C-IV, D-I
- (4) A-III, B-II, C-I, D-IV

49. Predict the major product "P" in the following sequence of reactions-

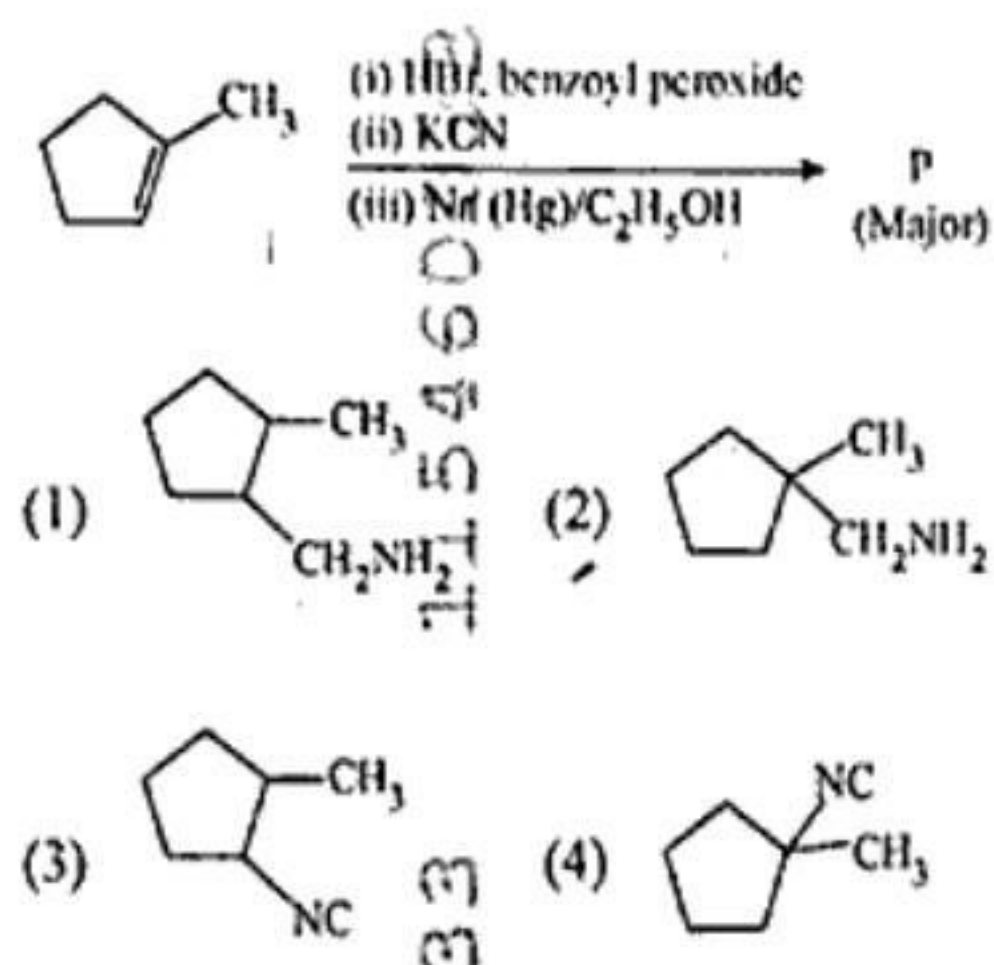

50. Energy and radius of first Bohr orbit of He^+ and Li^{2+} and

[Given: $R_H = 2.18 \times 10^{-18} \text{ J}$, $a_0 = 52.9 \text{ pm}$]

(1) $E_1(\text{Li}^{2+}) = -19.62 \times 10^{-18} \text{ J}$

$r_1(\text{Li}^{2+}) = 17.6 \text{ pm}$

$E_1(\text{He}^+) = -8.72 \times 10^{-18} \text{ J}$

$r_1(\text{He}^+) = 26.4 \text{ pm}$

(2) $E_1(\text{Li}^{2+}) = -8.72 \times 10^{-18} \text{ J}$

$r_1(\text{Li}^{2+}) = 26.4 \text{ pm}$

$E_1(\text{He}^+) = -19.62 \times 10^{-18} \text{ J}$

$r_1(\text{He}^+) = 17.6 \text{ pm}$

(3) $E_1(\text{Li}^{2+}) = -19.62 \times 10^{-16} \text{ J}$

$r_1(\text{Li}^{2+}) = 17.6 \text{ pm}$

$E_1(\text{He}^+) = -8.72 \times 10^{-16} \text{ J}$

$r_1(\text{He}^+) = 26.4 \text{ pm}$

(4) $E_1(\text{Li}^{2+}) = -8.72 \times 10^{-16} \text{ J}$,

$r_1(\text{Li}^{2+}) = 17.6 \text{ pm}$

$E_1(\text{He}^+) = -19.62 \times 10^{-16} \text{ J}$,

$$r_{\infty}(\text{He}^+) = 17.6 \text{ pm}$$

51. Which of the following are paramagnetic?

- A. $[\text{NiCl}_4]^{2-}$
- B. $\text{Ni}(\text{CO})_4$
- C. $[\text{Ni}(\text{CN})_4]^{2-}$
- D. $[\text{Ni}(\text{H}_2\text{O})_6]^{2+}$
- E. $\text{Ni}(\text{PPh}_3)_4$

Choose the correct answer from the options given below:

- (1) A and C only
- (2) B and E only
- (3) A and D only
- (4) A, D and E only

52. Give below are two statements:

Statement I: Like nitrogen that can form ammonia, arsenic can form arsine.

Statement II: Antimony cannot form antimony pentoxide.

In the light of the above statements, choose the most appropriate answer from the options given below:

- (1) Both Statement I and Statement II are correct
- (2) Both Statement I and Statement II are incorrect
- (3) Statement I is correct but Statement II is incorrect
- (4) Statement I is incorrect but Statement II is correct

53. Which among the following electronic configurations belong to main group elements?

- A. $[\text{Ne}]3s^1$
- B. $[\text{Ar}]3d^3 4s^2$
- C. $[\text{Kr}]4d^{10} 5s^2 5p^5$

D. $[\text{Ar}]3d^{10} 4s^1$

E. $[\text{Rn}]5f^0 6d^2 7s^2$

Choose the correct answer from the option given below:

(1) B and E only

(2) A and C only

(3) D and E only

(4) A, C and D only

54. Dalton's Atomic theory could not explain which of the following?

(1) Law of conservation of mass

(2) Law of constant proportion

(3) Law of multiple proportion

(4) Law of gaseous volume

55. Consider the following compounds: $\underline{K}O_2$, $H_2\underline{O}_2$ and $H_2\underline{S}O_4$. The oxidation states of the underlined elements in them are, respectively,

(1) +1, -1, and +6

(2) +2, -2, and +6

(3) +1, -2, and +4

(4) +4, -4, and +6

56. If the half-life ($t_{1/2}$) of a first order reaction is 1 minute, then the time required for 99.9% completion of the reaction is closest to:

(1) 2 minutes

(2) 4 minutes

(3) 5 minutes

(4) 10 minutes

57. The correct order of the wavelength of light absorbed by the following complexes is,

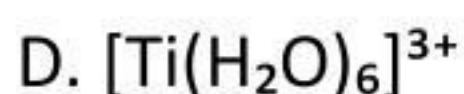
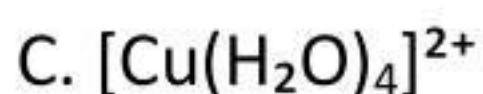
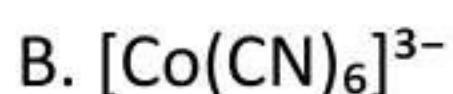
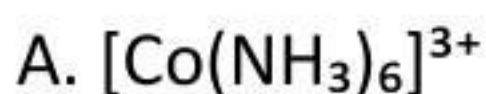

Choose the correct answer from the options given below:

(1) $B < D < A < C$

(2) $B < A < D < C$

(3) $C < D < A < B$

(4) $C < A < D < B$

58. Which one of the following compounds can exist as cis-trans isomers?

(1) Pent-1-ene

(2) 2-Methylhex-2-ene

(3) 1,1-Dimethylcyclopropane

(4) 1,2-Dimethylcyclohexane

59. Phosphoric acid ionizes in three steps with their ionization constant values

K_{a_1} , K_{a_2} and K_{a_3} respectively, while K is the overall ionization constant. Which of the following statements are true?

A. $\log K = \log K_{a_1} + \log K_{a_2} + \log K_{a_3}$

B. H_3PO_4 is a stronger acid than H_2PO_4^- and HPO_4^{2-}

C. $K_{a_1} > K_{a_2} > K_{a_3}$

D. $K_{a_1} = \frac{K_{a_3} + K_{a_2}}{2}$

Choose the correct answer from the options given below:

(1) A and B only

(2) A and C only

(3) B, C and D only

(4) A, B and C only

60. Which one of the following reactions does NOT give benzene as the product?

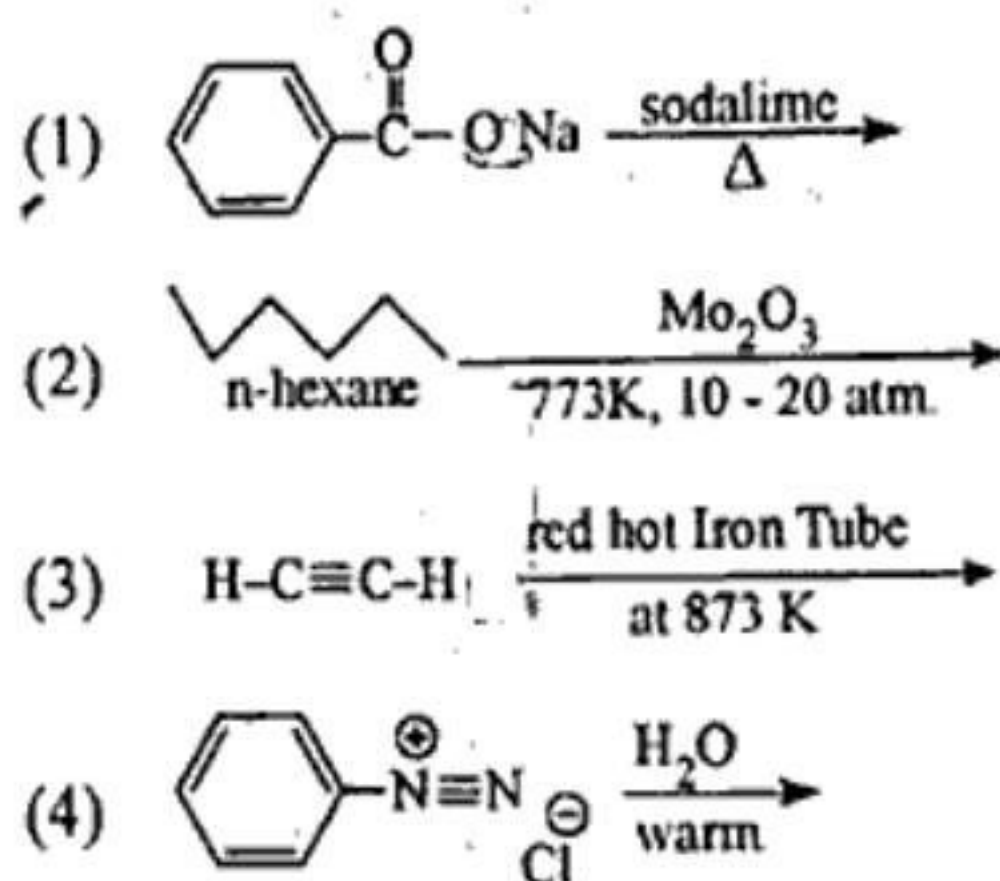

61. If the molar conductivity (Λ_m) of a 0.050 mol L⁻¹ solution of a monobasic weak acid is 90 S cm² mol⁻¹, its extent (degree) of dissociation will be

[Assume $\Lambda_+^0 = 346.6$ S cm² mol⁻¹ and Λ_-^0 (K⁺) = 50.4 S cm² mol⁻¹]

(1) 0.115

(2) 0.125

(3) 0.225

(4) 0.215

62. Given below are two statements:

Statement I: A hypothetical diatomic molecule with bond order zero is quite stable.

Statement II: As bond order increases, the bond length increases.

In the light of the above statements, choose the most appropriate answer from the options given below:

(1) Both Statement I and Statement II are true

(2) Both Statement I and Statement II are false

(3) Statement I is true but Statement II is false

(4) Statement I is false but Statement II is true

63. Out of the following complex compounds, which of the compound will be having the minimum conductance in solution?

- (1) $[\text{Co}(\text{NH}_3)_3\text{Cl}_3]$
- (2) $[\text{Co}(\text{NH}_3)_4\text{Cl}_2]$
- (3) $[\text{Co}(\text{NH}_3)_6]\text{Cl}_3$
- (4) $[\text{Co}(\text{NH}_3)_5\text{Cl}]\text{Cl}$

64. Match List - I with List - II

List-I	List-II
A. XeO_3	I. sp^3 , linear
B. XeF_2	II. sp^3 , pyramidal
C. XeOF_4	III. sp^3d^3 , distorted octahedral
D. XeF_6	IV. sp^3d^2 , square pyramidal

Choose the correct answer from the options given below:

- (1) A-II, B-I, C-IV, D-III
- (2) A-II, B-I, C-III, D-IV
- (3) A-IV, B-II, C-III, D-I
- (4) A-IV, B-II, C-I, D-III

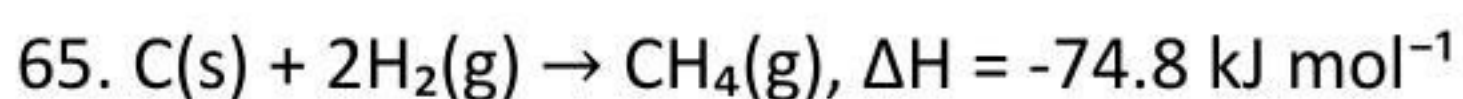

Which of the following diagrams gives an accurate representation of the above reaction?

[R \rightarrow reactants, P \rightarrow products]

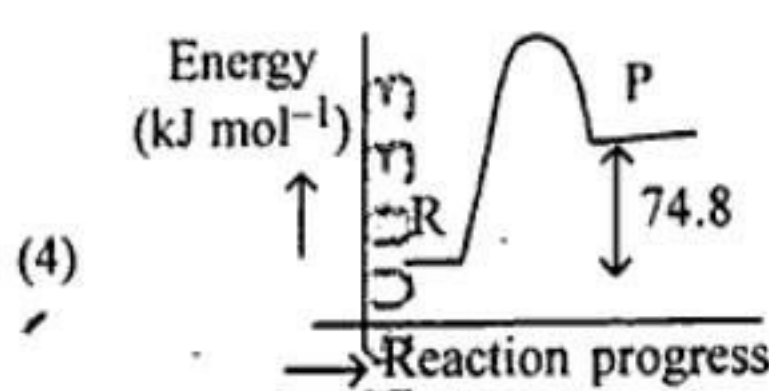
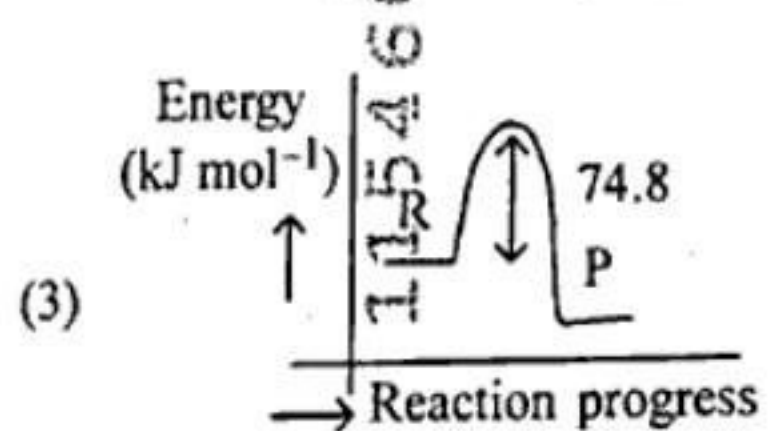
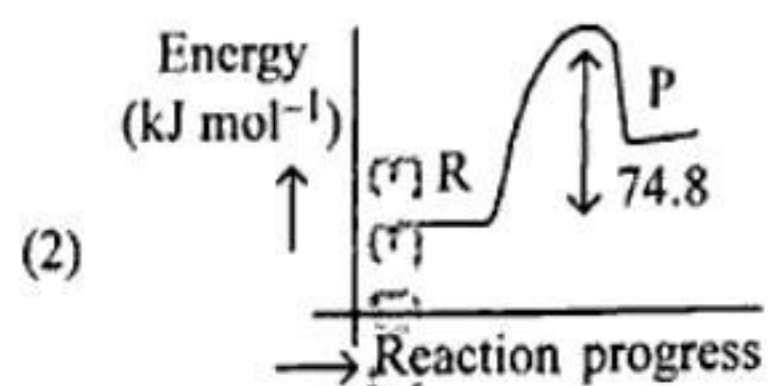
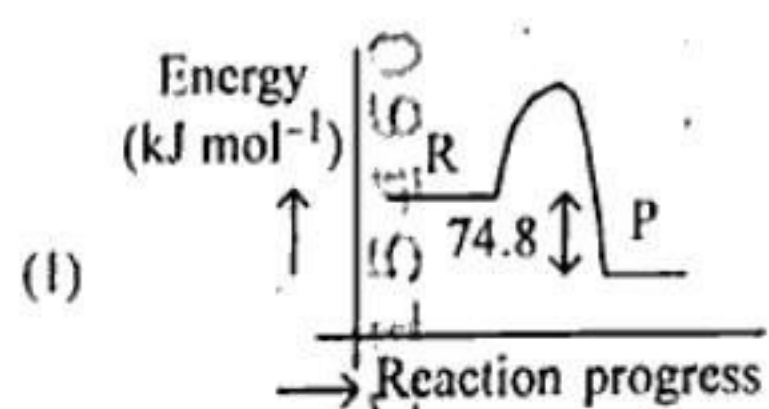

66. Match List - I with List - II

List-I (Example) List-II (Type of Solution)

- | | |
|-------------|----------------------|
| A. Humidity | I. Solid in gas |
| B. Alloys | II. Liquid in gas |
| C. Amalgams | III. Solid in liquid |
| D. Smoke | IV. Liquid in solid |

Choose the correct answer from the options given below:

- (1) A-II, B-IV, C-I, D-III
- (2) A-II, B-I, C-IV, D-III
- (3) A-III, B-I, C-IV, D-II
- (4) A-III, B-II, C-I, D-IV

67. The correct order of decreasing basic strength of the given amines is:

- (1) N-methylaniline > benzenamine > ethanamine > N-ethylethanamine
- (2) N-ethylethanamine > ethanamine > benzenamine > N-methylaniline

(3) N-methylaniline > ethanamine > N-ethylethanamine > benzenamine

(4) benzenamine > ethanamine > N-methylaniline > N-ethylethanamine

68. Among the following, choose the ones with equal number of atoms.

A. 212 g of $\text{Na}_2\text{CO}_3(\text{s})$ [molar mass = 106 g]

B. 248 g of $\text{Na}_2\text{O}_2(\text{s})$ [molar mass = 62 g]

C. 240 g of $\text{NaOH}(\text{s})$ [molar mass = 40 g]

D. 12 g of $\text{H}_2(\text{g})$ [molar mass = 2 g]

E. 220 g of $\text{CO}_2(\text{g})$ [molar mass = 44 g]

Choose the correct answer from the options given below:

(1) A, B, and C only

(2) A, B, and D only

(3) B, C, and D only

(4) B, D, and E only

69. Match List I with List II

List I (Name of Vitamin)	List II (Deficiency disease)
A. Vitamin B_{12}	I. Cheilosis
B. Vitamin D	II. Convulsions
C. Vitamin B_2	III. Rickets
D. Vitamin B_5	IV. Pernicious anaemia

Choose the correct answer from the options given below:

(1) A-I, B-III, C-II, D-IV

(2) A-IV, B-III, C-I, D-II

(3) A-II, B-III, C-I, D-IV

(4) A-IV, B-III, C-II, D-I

70. The correct order of decreasing acidity of the following aliphatic acids is:

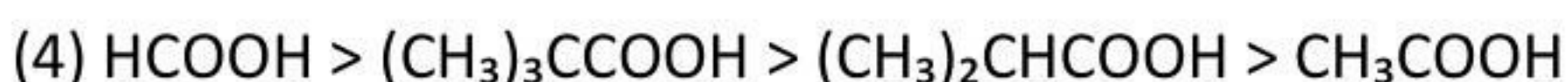

71. Given below are two statements:

Statement I: Ferromagnetism is considered as an extreme form of paramagnetism.

Statement II: The number of unpaired electrons in a Cr^{2+} ion ($Z = 24$) is the same as that of a Nd^{3+} ion ($Z = 60$).

In the light of the above statements, choose the correct answer from the options given below:

(1) Both Statement I and Statement II are true

(2) Both Statement I and Statement II are false

(3) Statement I is true but Statement II is false

(4) Statement I is false but Statement II is true

72. Match List I with List II

List I (Mixture)

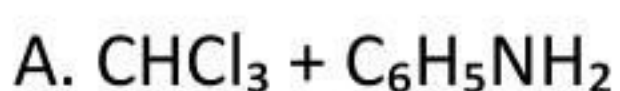

B. Crude oil in petroleum industry

C. Glycerol from spent-lye

D. Aniline – water

List II (Method of Separation)

I. Distillation under reduced pressure

II. Steam distillation

III. Fractional distillation

IV. Simple distillation

Choose the correct answer from the options given below:

(1) A-IV, B-III, C-I, D-II

(2) A-IV, B-III, C-II, D-I

(3) A-III, B-IV, C-I, D-II

(4) A-III, B-IV, C-II, D-I

73. For the reaction $A(g) \rightleftharpoons 2B(g)$, the backward reaction rate constant is higher than the forward reaction rate by a factor of 2500, at 1000 K.

[Given: $R = 0.083 \text{ L atm mol}^{-1} \text{ K}^{-1}$]

K_p for the reaction at 1000 K is

- (1) 83.1
- (2) 2.077×10^5
- (3) 0.033
- (4) 0.021

74. Given below are two statements:

Statement I: Benzenediazonium salt is prepared by the reaction of aniline with nitrous acid at 273 – 278K. It decomposes easily in the dry state.

Statement II: Insertion of iodine into the benzene ring is difficult and hence iodobenzene is prepared through the reaction of benzenediazonium salt with KI.

In the light of the above statements, choose the most appropriate answer from the options given below:

- (1) Both Statement I and Statement II are correct
- (2) Both Statement I and Statement II are incorrect
- (3) Statement I is correct but Statement II is incorrect
- (4) Statement I is incorrect but Statement II is correct

75. How many products (including stereoisomers) are expected from monochlorination of the following compound?

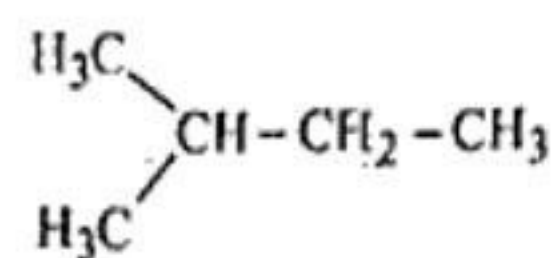

- (1) 2
- (2) 3
- (3) 5
- (4) 6

76. Among the given compounds I-III, the correct order of bond dissociation energy of C-H bond marked with * is:

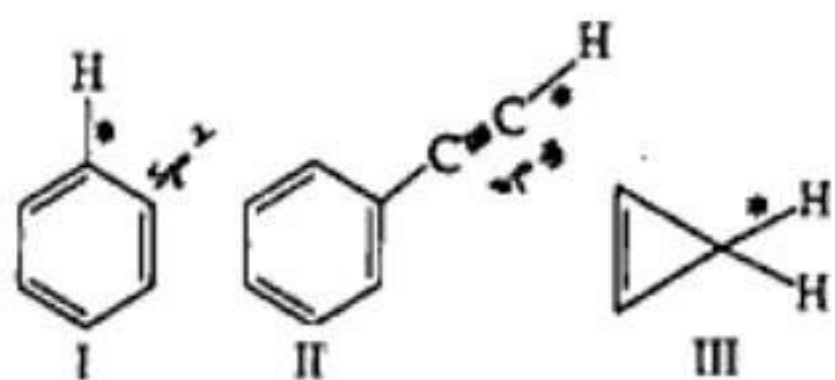

- (1) II > I > III
- (2) I > II > III
- (3) III > II > I
- (4) II > III > I

77. Which one of the following compounds does not decolourize bromine water?

- (1)
- (2)
- (3)
- (4)

78. The major product of the following reaction is :

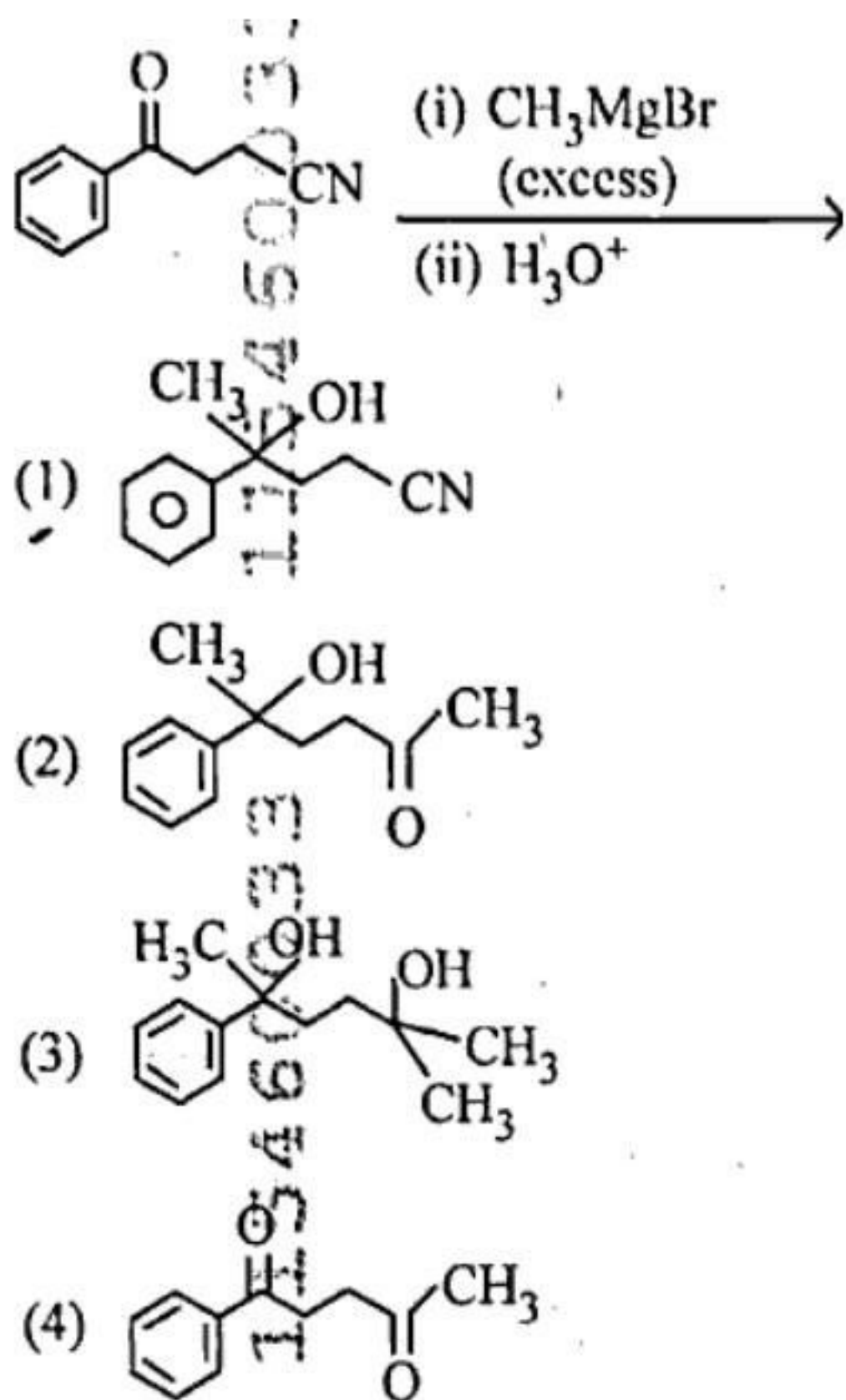

79. Which of the following aqueous solution will exhibit highest boiling point?

- (1) 0.01M Urea
- (2) 0.01M KNO_3
- (3) 0.01M Na_2SO_4
- (4) 0.015M $\text{C}_6\text{H}_{12}\text{O}_6$

80. Match List I with List - II

List-I	List-II
A. Haber process	I. Fe catalyst
B. Wacker oxidation	II. PdCl_2
C. Wilkinson catalyst	III. $[(\text{Ph}_3\text{P})_3\text{RhCl}]$
D. Ziegler catalyst	IV. TiCl_4 with $\text{Al}(\text{CH}_3)_3$

Choose the correct answer from the options given below:

- (1) A-I, B-II, C-IV, D-III
- (2) A-II, B-III, C-I, D-IV

(3) A-I, B-II, C-III, D-IV

(4) A-I, B-IV, C-III, D-II

81. 5 moles of liquid X and 10 moles of liquid Y make a solution having a vapour pressure of 70 torr. The vapour pressures of pure X and Y are 63 torr and 78 torr respectively. Which of the following is true regarding the described solution?

(1) The solution shows positive deviation.

(2) The solution shows negative deviation.

(3) The solution is ideal.

(4) The solution has volume greater than the sum of individual volumes.

82. Sugar 'X' is

A. is found in honey.

B. is a keto sugar.

C. exists in α and β - anomeric forms.

D. is laevorotatory.

'X' is :

(1) D-Glucose

(2) D-Fructose

(3) Maltose

(4) Sucrose

83. Identify the suitable reagent for the following conversion.

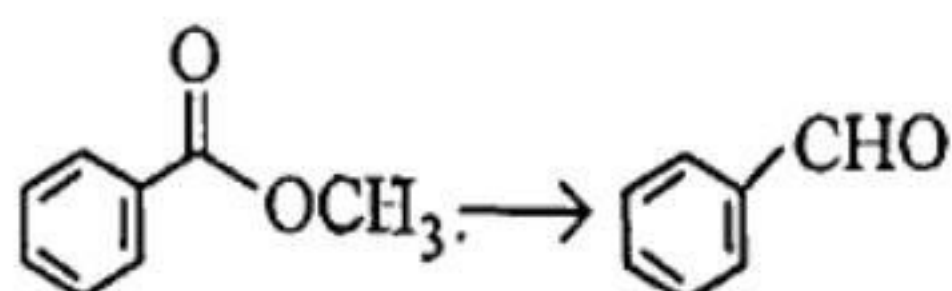

(1) (i) LiAlH_4 , (ii) $\text{H}^+/\text{H}_2\text{O}$

(2) (i) $\text{AlH}(\text{iBu})_2$, (ii) H_2O

(3) (i) NaBH_4 , (ii) $\text{H}^+/\text{H}_2\text{O}$

(4) $\text{H}_2/\text{Pd}-\text{BaSO}_4$

84. Given below are two statements: One is labelled as Assertion (A) and the other is labelled as Reason (R).

Assertion (A) :  I undergoes $\text{S}_{\text{N}}2$ reaction faster than  Cl.

Reason (R) : Iodine is a better leaving group because of its large size.

In the light of the above statements, choose the correct answer from the options given below:

- (1) Both A and R are true and R is the correct explanation of A
- (2) Both A and R are true but R is NOT the correct explanation of A
- (3) A is true but R is false
- (4) A is false but R is true

85. The standard heat of formation, in kcal/mol of Ba^{2+} is:

[Given: standard heat of formation of SO_4^{2-} ion(aq) = -216 kcal/mol, standard heat of crystallization of

$\text{BaSO}_4(\text{s}) = -4.5$ kcal/mol, standard heat of formation of $\text{BaSO}_4(\text{s}) = -349$ kcal/mol]

- (1) -128.5
- (2) -133.0
- (3) +133.0
- (4) +220.5

86. Total number of possible isomers (both structural as well as stereoisomers) of cyclic ethers of molecular formula $\text{C}_4\text{H}_8\text{O}$ is:

- (1) 6
- (2) 8
- (3) 10
- (4) 11

87. Identify the correct orders against the property mentioned:

A. $\text{H}_2\text{O} > \text{NH}_3 > \text{CHCl}_3$ - dipole moment

B. $\text{XeF}_4 > \text{XeO}_3 > \text{XeF}_2$ - number of lone pairs on central atom

C. $\text{O-H} > \text{C-H} > \text{N-O}$ - bond length

D. $\text{N}_2 > \text{O}_2 > \text{H}_2$ - bond enthalpy

Choose the correct answer from the options given below:

(1) A, D only

(2) B, D only

(3) A, C only

(4) B, C only

88. Higher yield of NO in $\text{N}_2(\text{g}) + \text{O}_2(\text{g}) \rightleftharpoons 2\text{NO}(\text{g})$ can be obtained at

$[\Delta H \text{ of the reaction} = +180.7 \text{ kJ mol}^{-1}]$

A. higher temperature

B. lower temperature

C. higher concentration of N_2

D. higher concentration of O_2

Choose the correct answer from the options given below:

(1) A, D only

(2) B, C only

(3) B, C, D only

(4) A, C, D only

89. If the rate constant of a reaction is 0.03 s^{-1} , how much time does it take for 7.2 mol L^{-1} concentration of the reactant to get reduced to 0.9 mol L^{-1} ?

[Given: $\log 2 = 0.301$]

(1) 69.3 s

(2) 23.1 s

(3) 210 s

(4) 21.0 s

90. Which one of the following reactions does NOT belong to "Lassaigne's test"?

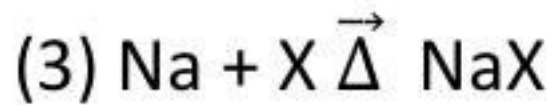
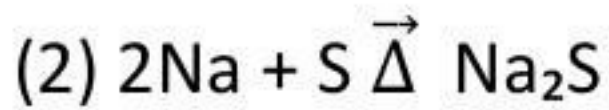
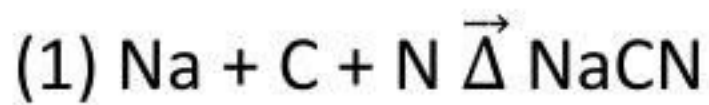

91. The complex II of mitochondrial electron transport chain is also known as:

(1) Cytochrome bc_1

(2) Succinate dehydrogenase

(3) Cytochrome c oxidase

(4) NADH dehydrogenase

92. Polymerase chain reaction (PCR) amplifies DNA following the equation:

(1) N^2

(2) 2^n

(3) $2n + 1$

(4) $2N^2$

93. What are the potential drawbacks in adoption of IVF method?

A. High fatality risk to mother

B. Expensive instruments and reagents

C. Husband/wife necessary for being donors

D. Less adoption of orphans

E. Not available in India

F. Possibility that the early embryo does not survive

Choose the correct answer from the options given below:

- (1) B, D, F only
- (2) A, C, D, F only
- (3) A, B, C, D only
- (4) A, B, C, E, F only

94. What is the name of the blood vessel that carries deoxygenated blood from the body to the heart in a frog?

- (1) Aorta
- (2) Pulmonary artery
- (3) Pulmonary vein
- (4) Vena cava

95. Which one of the following statements refers to Reductionist Biology?

- (1) Physico-chemical approach to study and understand living organisms
- (2) Physiological approach to study and understand living organisms
- (3) Chemical approach to study and understand living organisms
- (4) Behavioural approach to study and understand living organisms

96. Given below are two statements:

Statement I: In the RNA world, RNA is considered the first genetic material evolved to carry out essential life processes. RNA acts as a genetic material and also as a catalyst for some important biochemical reactions in living systems. Being reactive, RNA is unstable.

Statement II: DNA evolved from RNA and is a more stable genetic material. Its double helical strands being complementary, resist changes by evolving repairing mechanism.

In the light of the above statements, choose the most appropriate answer from the options given below:

- (1) Both statement I and statement II are correct

- (2) Both statement I and statement II are incorrect
- (3) Statement I is correct but statement II is incorrect
- (4) Statement I is incorrect but statement II is correct

97. Epiphytes that are growing on a mango branch is an example of which of the following?

- (1) Commensalism
- (2) Mutualism
- (3) Predation
- (4) Amensalism

98. From the statements given below choose the correct option:

- A. The eukaryotic ribosomes are 80S and prokaryotic ribosomes are 70 S.
- B. Each ribosome has two sub-units.
- C. The two sub-units of 80S ribosome are 60S and 40S while that of 70S are 50S and 30S.
- D. The two sub-units of 80S ribosome are 60S and 20S and that of 70S are 50S and 20S.
- E. The two sub-units of 80S are 60S and 30S and that of 70S are 50S and 30S.

- (1) A, B, C are true
- (2) A, B, D are true
- (3) A, B, E are true
- (4) B, D, E are true

99. Which one of the following is an example of ex-situ conservation?

- (1) National Park
- (2) Wildlife Sanctuary
- (3) Zoos and botanical gardens
- (4) Protected areas

100. Given below are two statements:

Statement I: The primary source of energy in an ecosystem is solar energy.

Statement II: The rate of production of organic matter during photosynthesis in an ecosystem is called net primary productivity (NPP).

In the light of the above statements, choose the most appropriate answer from the options given below:

- (1) Both statement I and statement II are correct
- (2) Both statement I and statement II are incorrect
- (3) Statement I is correct but statement II is incorrect
- (4) Statement I is incorrect but statement II is correct

101. Match List - I with List - II

List - I

List - II

A. Emphysema

I. Rapid spasms in muscle due to low Ca^{++} in body fluid

B. Angina Pectoris

II. Damaged alveolar walls and decreased respiratory surface

III. Acute chest pain when not enough oxygen is reaching to heart muscle

C. Glomerulonephritis

IV. Inflammation of glomeruli of kidney

D. Tetany

Choose the correct answer from the options given below:

- (1) A-III, B-I, C-IV, D-II
- (2) A-III, B-I, C-II, D-IV
- (3) A-II, B-IV, C-III, D-I
- (4) A-II, B-III, C-IV, D-I

102. Given below are two statements: One is labelled as Assertion (A) and the other is labelled as Reason (R).

Assertion (A): Both wind and water pollinated flowers are not very colourful and do not produce nectar.

Reason (R): The flowers produce enormous amount of pollen grains in wind and water pollinated flowers.

In the light of the above statements, choose the correct answer from the options given below:

- (1) Both A and R are true and R is the correct explanation of A
- (2) Both A and R are true but R is NOT the correct explanation of A
- (3) A is true but R is false
- (4) A is false but R is true

103. Which of the following is an example of non-distilled alcoholic beverage produced by yeast?

- (1) Whisky
- (2) Brandy
- (3) Beer
- (4) Rum

104. Given below are two statements:

Statement I: In a floral formula \oplus stands for zygomorphic nature of the flower, and \underline{G} stands for inferior ovary.

Statement II: In a floral formula \oplus stands for actinomorphic nature of the flower and \underline{G} stands for superior ovary.

In the light of the above statements, choose the correct answer from the options given below:

- (1) Both Statement I and Statement II are correct
- (2) Both Statement I and Statement II are incorrect
- (3) Statement I is correct but Statement II is incorrect
- (4) Statement I is incorrect but Statement II is correct

105. Streptokinase is produced by bacterium Streptococcus for

- (1) Curd production
- (2) Ethanol production
- (3) Liver disease treatment
- (4) Removing clots from blood vessels

106. Which chromosome in the human genome has the highest number of genes?

- (1) Chromosome X
- (2) Chromosome Y
- (3) Chromosome 1
- (4) Chromosome 10

107. Which of the following statement is correct about location of the male frog copulatory pad?

- (1) First and second digit of fore limb
- (2) First digit of hind limb
- (3) Second digit of fore limb
- (4) First digit of the fore limb

108. Which one of the following phytohormones promotes nutrient mobilization which helps in the delay of leaf senescence in plants?

- (1) Ethylene
- (2) Abscisic acid
- (3) Gibberellin
- (4) Cytokinin

109. While trying to find the characteristic of a newly found animal, a researcher did the histology of adult animal and observed a cavity with presence of mesodermal

tissue towards the body wall but no mesodermal tissue was observed towards the alimentary canal. What will be the possible coelome of that animal?

- (1) Acoelomate
- (2) Pseudocoelomate
- (3) Schizocoelomate
- (4) Spongocoelomate

110. Match List - I with List – II

List - I	List - II
A. Head	I. Enzymes
B. Middle piece	II. Sperm motility
C. Acrosome	III. Energy
D. Tail	IV. Genetic material

Choose the correct answer from the options given below:

- (1) A-IV, B-III, C-I, D-II
- (2) A-IV, B-III, C-II, D-I
- (3) A-III, B-IV, C-II, D-I
- (4) A-III, B-II, C-I, D-IV

111. Given below are the stages in the life cycle of pteridophytes. Arrange the following stages in the correct sequence: <https://www.validcollege.com>

- A. Prothallus stage
- B. Meiosis in spore mother cells
- C. Fertilisation
- D. Formation of archegonia and antheridia in gametophyte
- E. Transfer of antherozoids to the archegonia in presence of water.

Choose the correct answer from the options given below:

- (1) B, A, D, E, C
- (2) B, A, E, C, D

(3) D, E, C, A, B

(4) E, D, C, B, A

112. Cardiac activities of the heart are regulated by:

A. Nodal tissue

B. A special neural centre in the medulla oblongata

C. Adrenal medullary hormones

D. Adrenal cortical hormones

Choose the correct answer from the options given below:

(1) A, B and C only

(2) A, B, C and D only

(3) A, C and D only

(4) A, B and D only

113. Which of the following organisms cannot fix nitrogen?

A. Azotobacter

B. Oscillatoria

C. Anabaena

D. Volvox

E. Nostoc

Choose the correct answer from the options given below:

(1) A only

(2) D only

(3) B only

(4) E only

114. Given below are two statements:

STATEMENT I: Transfer RNAs do not interact with ribosomal RNA.

STATEMENT II: RNA interference (RNAi) takes place in all eukaryotic organisms as a method of cellular defence.

In the light of the above statements, choose the most appropriate answer from the options given below:

- (1) Both Statement I and Statement II are correct
- (2) Both Statement I and Statement II are incorrect
- (3) Statement I is correct but Statement II is incorrect
- (4) Statement I is incorrect but Statement II is correct

115.

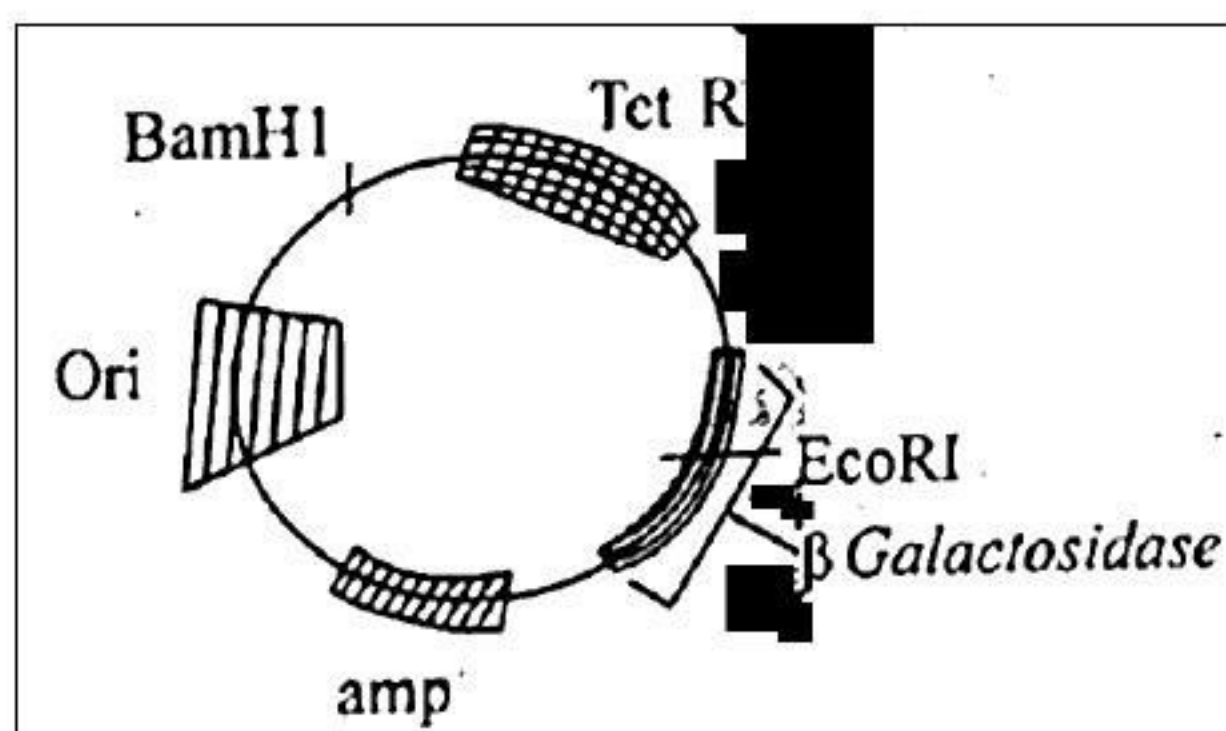

In the above represented plasmid an alien piece of DNA is inserted at EcoRI site. Which of the following recombinant colonies will be chosen to select the recombinants?

- (1) Using ampicillin & tetracycline containing medium plate
- (2) Blue color colonies will be selected
- (3) White color colonies will be selected
- (4) Blue color colonies grown on ampicillin plates can be selected.

116. Which of the following genetically engineered organisms was used by Eli Lilly to prepare human insulin?

- (1) Bacterium
- (2) Yeast
- (3) Virus
- (4) Phage

117. Name the class of enzyme that usually catalyze the following reaction:

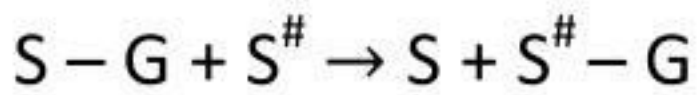

Where, G → a group other than hydrogen

S → a substrate

S[#] → another substrate

- (1) Hydrolase
- (2) Lyase
- (3) Transferase
- (4) Ligase

118. Find the statement that is NOT correct with regard to the structure of monocot stem.

- (1) Hypodermis is parenchymatous
- (2) Vascular bundles are scattered
- (3) Vascular bundles are conjoint and closed
- (4) Phloem parenchyma is absent

119. The correct sequence of events in the life cycle of bryophytes is

- A. Fusion of antherozoid with egg.
- B. Attachment of gametophyte to substratum.
- C. Reduction division to produce haploid spores.
- D. Formation of sporophyte.
- E. Release of antherozoids into water.

Choose the correct answer from the options given below:

- (1) D, E, A, C, B
- (2) B, E, A, C, D
- (3) B, E, A, D, C
- (4) D, E, A, B, C

120. Which are correct:

- A. Computed tomography and magnetic resonance imaging detect cancers of internal organs
- B. Chemotherapeutics drugs are used to kill non-cancerous cells
- C. α -interferon activate the cancer patients' immune system and helps in destroying the tumour.
- D. Chemotherapeutic drugs are biological response modifiers
- E. In the case of leukaemia blood cell counts are decreased

Choose the correct answer from the options given below:

- (1) B and D only
- (2) D and E only
- (3) C and D only
- (4) A and C only

121. Match List – I with List – II

List – I

List – II

- | | |
|------------------|--------------------------|
| A. Centromere | I. Mitochondrion |
| B. Cilium | II. Cell division |
| C. Cristae | III. Cell movement |
| D. Cell membrane | IV. Phospholipid Bilayer |

Choose the correct answer from the options given below:

- (1) A-I, B-II, C-III, D-IV
- (2) A-II, B-I, C-IV, D-III
- (3) A-IV, B-II, C-III, D-I
- (4) A-II, B-III, C-I, D-IV

122. Match List I with List II

List I

List II

- A. Chlorophyll a I. Yellow-green
B. Chlorophyll b II. Yellow
C. Xanthophylls III. Blue-green
D. Carotenoids IV. Yellow to Yellow -orange

Choose the option with all correct matches

- (1) A-III, B-IV, C-II, D-I
(2) A-III, B-I, C-II, D-IV
(3) A-I, B-II, C-IV, D-III
(4) A-I, B-IV, C-III, D-II

123. Find the correct statements:

- A. In human pregnancy, the major organ systems are formed at the end of 12 weeks
B. In human pregnancy the major organ systems are formed at the end of 8 weeks
C. In human pregnancy heart is formed after one month of gestation
D. In human pregnancy, limbs and digits develop by the end of second month
E. In human pregnancy the appearance of hair is usually observed in the fifth month

Choose the correct answer from the options given below:

- (1) A and E only
(2) B and C only
(3) B, C, D and E only
(4) A, C, D and E only

124. In the seeds of cereals, the outer covering of the endosperm separates the embryo by a protein-rich layer called:

- (1) Coleoptile
(2) Coleorhiza
(3) Integument
(4) Aleurone layer

125. Which of the following diagrams is correct with regard to the proximal (P) and distal (D) tubule of the Nephron.

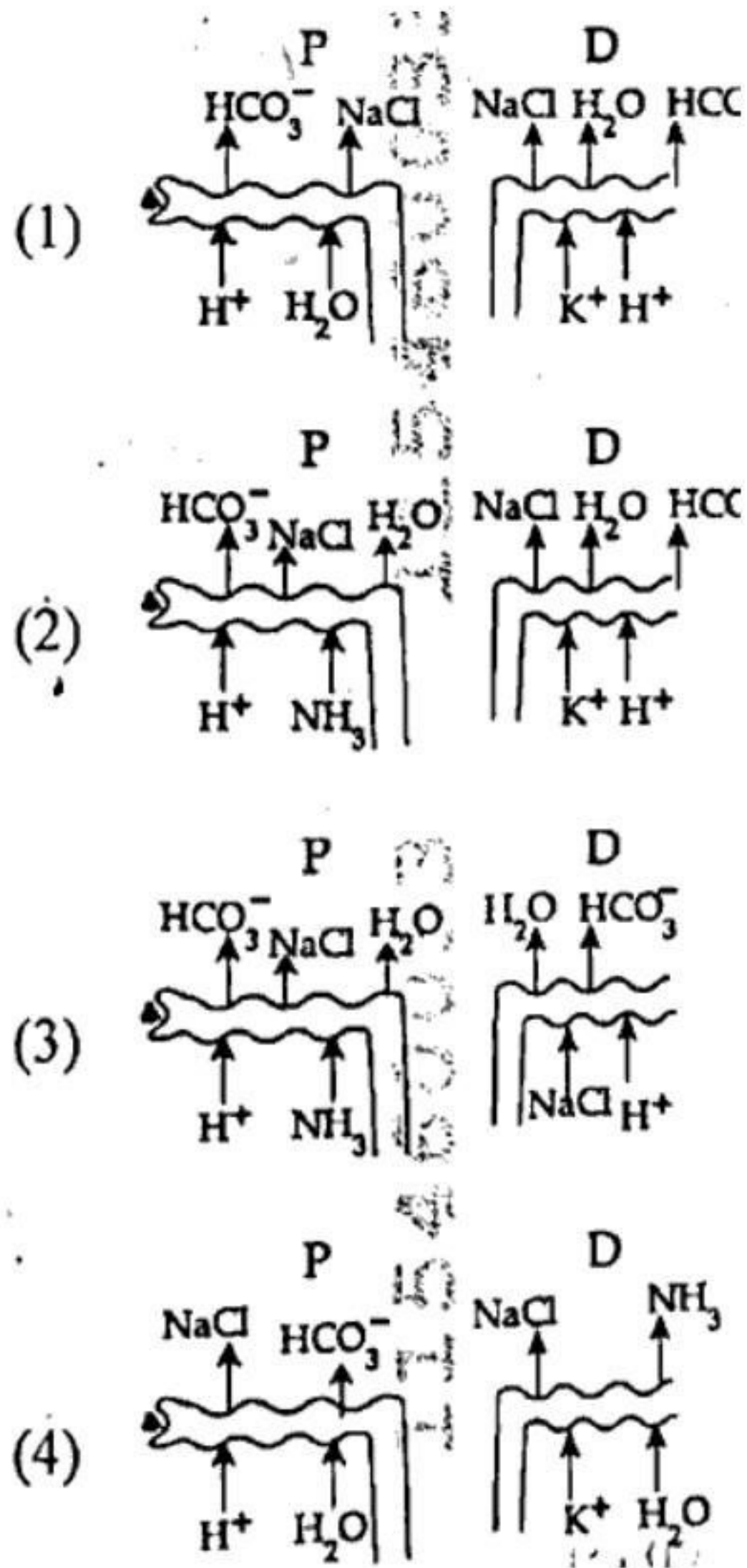

126. Identify the part of a bio-reactor which is used as a foam breaker from the given figure.

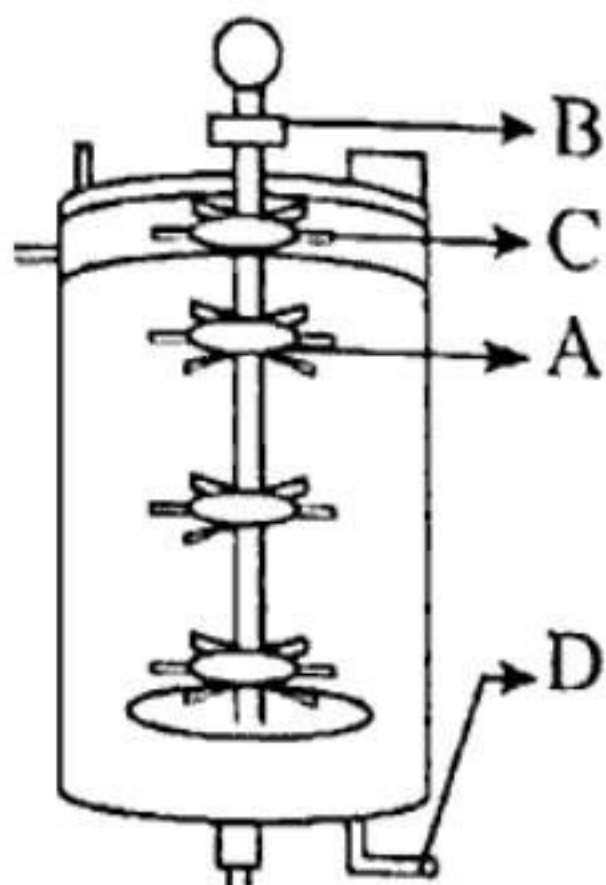

- (1) A
- (2) B
- (3) D
- (4) C

127. Given below are two statements: One is labelled as Assertion (A) and the other is labelled as Reason (R):

Assertion (A): A typical unfertilised angiosperm embryo sac at maturity is 8 nucleate & 7-celled

Reason (R): The egg apparatus has 2 polar nuclei

In the light of the above statements, choose the correct answer from the options given below:

- (1) Both A and R are true and R is the correct explanation of A
- (2) Both A and R are true but R is NOT the correct explanation of A
- (3) A is true but R is false
- (4) A is false but R is true

128. A specialised membranous structure in a prokaryotic cell which helps in cell wall formation, DNA replication and respiration is:

- (1) Mesosome
- (2) Chromophores
- (3) Cristae
- (4) Endoplasmic Reticulum

129. Which of the following are the post-transcriptional events in a eukaryotic cell?

- A. Transport of premRNA to cytoplasm prior to splicing
- B. Removal of introns and joining of exons
- C. Addition of methyl group at 5' end of hnRNA
- D. Addition of adenine residues at 3' end of hnRNA

E. Base pairing of two complementary RNAs

Choose the correct answer from the options given below:

(1) A, B, C only

(2) B, C, D only

(3) B, C, E only

(4) C, D, E only

130. What is the pattern of inheritance for polygenic trait?

(1) Mendelian inheritance pattern

(2) Non-mendelian inheritance pattern

(3) Autosomal dominant pattern

(4) X-linked recessive inheritance pattern

131. Which one of the following enzymes contains 'Haem' as the prosthetic group?

(1) RuBisCo

(2) Carbonic anhydrase

(3) Succinate dehydrogenase

(4) Catalase

132. Each of the following characteristics represents a kingdom proposed by Whittaker. Arrange the following in increasing order of complexity of body organization

A. Multicellular heterotrophs with cell wall made of chitin

B. Heterotrophs with tissue/organ/organ system level of body organization

C. Prokaryotes with cell wall made of polysaccharides and amino acids

D. Eukaryotic autotrophs with tissue/organ level of body organization

E. Eukaryotes with cellular body organization

Choose the correct answer from the options given below:

(1) A, C, E, B, D

- (2) C, E, A, D, B
- (3) A, C, E, D, B
- (4) C, E, A, B, D

133. Who is known as the father of Ecology in India?

- (1) S.R. Kashyap
- (2) Ramdeo Misra
- (3) Ram Udar
- (4) Birbal Sahni

134. Match List I with List II

List I	List II
A. Alfred Hershey and Martha Chase	I. Streptococcus pneumoniae
B. Euchromatin	II. Densely packed and dark stained
C. Frederick Griffith	III. Loosely packed and light-stained
D. Heterochromatin	IV. DNA as genetic material confirmation

Choose the correct answer from the options given below:

- (1) A-II, B-IV, C-I, D-III
- (2) A-IV, B-II, C-I, D-III
- (3) A-IV, B-III, C-I, D-II
- (4) A-III, B-II, C-IV, D-I

135. Neoplastic characteristics of cells refer to:

- A. A mass of proliferating cells
- B. Rapid growth of cells
- C. Invasion and damage to the surrounding tissue
- D. Those confined to original location

Choose the correct answer from the options given below:

- (1) A, B only
- (2) A, B, C only
- (3) A, B, D only
- (4) B, C, D only

136. Given below are two statements:

STATEMENT I: The DNA fragments extracted from gel electrophoresis can be used in construction of recombinant DNA

STATEMENT II: Smaller size DNA fragments are observed near anode while larger fragments near the wells in an agarose gel

In the light of the above statements, choose the most appropriate answer from the options given below:

- (1) Both statement I and statement II are correct
- (2) Both statement I and statement II are incorrect
- (3) Statement I is correct but statement II is incorrect
- (4) Statement I is incorrect but statement II is correct

137. Match List I with List II

List I	List II
A. Adenosine	I. Nitrogen base
B. Adenylic acid	II. Nucleotide
C. Adenine	III. Nucleoside
D. Alanine	IV. Amino acid

Choose the option with all correct matches

- (1) A-III, B-IV, C-II, D-I
- (2) A-III, B-II, C-IV, D-I
- (3) A-III, B-II, C-I, D-IV
- (4) A-II, B-III, C-I, D-IV

138. Consider the following:

- A. The reductive division for the human female gametogenesis starts earlier than that of the male gametogenesis
- B. The gap between the first meiotic division and the second meiotic division is much shorter for males compared to females
- C. The first polar body is associated with the formation of the primary oocyte
- D. Luteinizing Hormone (LH) surge leads to disintegration of the endometrium and onset of menstrual bleeding

Choose the correct answer from the options given below:

- (1) A and B are true
- (2) A and C are true
- (3) B and D are true
- (4) B and C are true

139. All living members of the class Cyclostomata are:

- (1) Free living
- (2) Endoparasite
- (3) Symbiotic
- (4) Ectoparasite

140. Given below are two statements: one is labelled as Assertion (A) and the other is labelled as Reason (R)

Assertion (A): The primary function of the Golgi apparatus is to package the materials made by the endoplasmic reticulum and deliver it to intracellular targets and outside the cell

Reason (R): Vesicles containing materials made by the endoplasmic reticulum fuse with the cis face of the Golgi apparatus, and face are modified and released from the trans face of the Golgi apparatus

In the light of the above statements, choose the correct answer from the options given below:

- (1) Both A and R are true and R is the correct explanation of A
- (2) Both A and R are true but R is not the correct explanation of A
- (3) A is true but R is false
- (4) A is false but R is true

141. Match List I with List II

List I	List II
A. Scutellum	I. Persistent nucellus
B. Non-albuminous seed	II. Cotyledon of monocot seed
C. Epiblast	III. Groundnut
D. Perisperm	IV. Rudimentary cotyledon

Choose the option with all correct matches

- (1) A-II, B-III, C-IV, D-I
- (2) A-IV, B-III, C-II, D-I
- (3) A-IV, B-III, C-I, D-II
- (4) A-II, B-IV, C-III, D-I

142. Given below are two statements: one is labelled as Assertion (A) and the other is labelled as Reason (R)

Assertion (A): All vertebrate chordates are not vertebrate

Reason (R): The members of subphylum vertebrata possess notochord during the embryonic period, the notochord is replaced by a cartilaginous or bony vertebral column in adults

In the light of the above statements, choose the correct answer from the options given below:

- (1) Both A and R are true and R is the correct explanation of A
- (2) Both A and R are true but R is not the correct explanation of A

- (3) A is true but R is false
- (4) A is false but R is true

143. Identify the statement that has NOT correct

- (1) Each antibody has two light and two heavy chains
- (2) The heavy and light chains are held together by disulfide bonds
- (3) Antigen binding site is located at C-terminal region of antibody molecules
- (4) Constant region of heavy and light chains are located at C-terminal region of antibody molecules

144. Silencing Of Specific Mrna Is Possible Via Rnai Because Of -

- (1) Complementary dsRNA
- (2) Inhibitory ssRNA
- (3) Complementary lRNA
- (4) Non-complementary ssRNA"

145. Genes r and y follow independent assortment. If rryy produce round yellow seeds and rryy produce wrinkled green seeds, what will be the phenotypic ratio of the F2 generation? <https://www.validcollege.com>

- (1) Phenotypic Ratio - 1 : 2 : 1
- (2) Phenotypic Ratio - 3 : 1
- (3) Phenotypic Ratio - 9 : 3 : 3 : 1
- (4) Phenotypic Ratio - 9 : 7

146. Histones Are Enriched With -

- (1) Lysine & Arginine
- (2) Leucine & Lysine
- (3) Phenylalanine & Leucine
- (4) Phenylalanine & Arginine

147. The First Menstruation Is Called :

- (1) Menopause
- (2) Menarche
- (3) Diapause
- (4) Ovulation

148. Match List - I with List - II

List - I	List - II
A. Heart	I. Erythropoietin
B. Kidney	II. Aldosterone
C. Gastro-intestinal tract	III. Atrial natriuretic factor
D. Adrenal cortex	IV. Secretin

Choose the correct answer from the options given below :

- (1) A-II, B-I, C-III, D-IV
- (2) A-IV, B-III, C-II, D-I
- (3) A-I, B-III, C-IV, D-II
- (4) A-III, B-I, C-IV, D-II

149. The protein portion of an enzyme is called :

- (1) Cofactor
- (2) Coenzyme
- (3) Apoenzyme
- (4) Prosthetic Group

150. Which of the following is the unit of productivity of an ecosystem?

- (1) gm^{-2}
- (2) Kcal m^{-2}
- (3) Kcal m^{-3}
- (4) $(\text{Kcal m}^{-2})\text{yr}^{-1}$

151. Sweet potato and potato represent a certain type of evolution. Select the correct combination of terms to explain the evolution.

- (1) Analogy, convergent
- (2) Homology, divergent
- (3) Homology, convergent
- (4) Analogy, divergent

152. With the help of given pedigree, find out the probability for the birth of a child having no mutation and being a carrier (has the disease mutation in one allele of the gene) in F_3 generation.

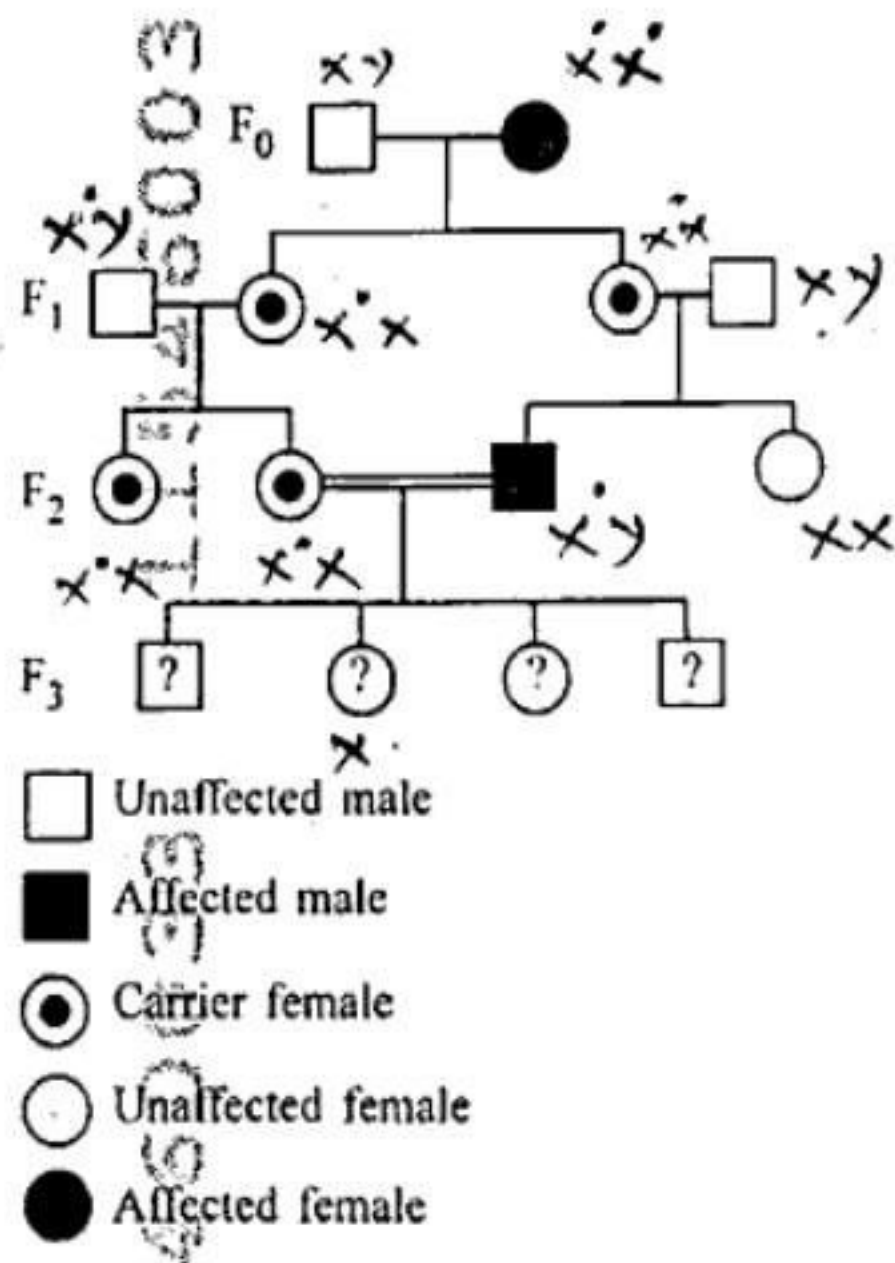

- (1) $1/4$
- (2) $1/2$
- (3) $1/8$
- (4) zero

153. Given below are two statements : one is labelled as assertion (A) and the other is labelled as reason (R).

Assertion (A) : cells of the tapetum possess dense cytoplasm and generally have more than one nucleus.

Reason (R) : presence of more than one nucleus in the tapetum increases the efficiency of nourishing the developing microspore mother cells.

In light of the above statements, choose the most appropriate answer from the options given below :

- (1) Both A and R are true and R is the correct explanation of A
- (2) Both A and R are true but R is not the correct explanation of A
- (3) A is true but R is false
- (4) A is false but R is true

154. How many meiotic and mitotic divisions need to occur for the development of a mature female gametophyte from the megaspore mother cell in an angiosperm plant?

- (1) 2 meiosis and 3 mitosis
- (2) 1 meiosis and 2 mitosis
- (3) 1 meiosis and 3 mitosis
- (4) No meiosis and 2 mitosis

155. Which of the following is an example of a zygomorphic flower?

- (1) petunia
- (2) datura
- (3) pea
- (4) chilli

156. After maturation, in primary lymphoid organs, the lymphocytes migrate for interaction with antigens to secondary lymphoid organ(s) / tissue(s) like:

A. Thymus

- B. Bone marrow
- C. Spleen
- D. Lymph nodes
- E. Peyer's patches

Choose the correct answer from the options given below:

- (1) B, C, D only
- (2) A, B, C only
- (3) E, A, B only
- (4) C, D, E only

157. Given below are two statements:

Statement I: fig fruit is a non-vegetarian fruit as it has enclosed fig wasps in it.

Statement II: fig wasp and fig tree exhibit mutual relationship as fig wasp completes its life cycle in fig fruit and fig fruit gets pollinated by fig wasp.

In the light of the above statements, choose the most appropriate answer from the options given below:

- (1) Both statement I and statement II are correct
- (2) Both statement I and statement II are incorrect
- (3) Statement I is correct but statement II is incorrect
- (4) Statement I is incorrect but statement II is correct

158. What is the main function of the spindle fibers during mitosis?

- (1) To separate the chromosomes
- (2) To synthesize new DNA
- (3) To repair damaged DNA
- (4) To regulate cell growth

159. Which one of the following is the characteristic feature of gymnosperms?

- (1) Seeds are enclosed in fruits

- (2) Seeds are naked
- (3) Seeds are absent
- (4) Gymnosperms have flowers for reproduction

160. Consider the following statements regarding function of adrenal medullary hormones:

- A. It causes pupillary constriction
- B. It is a hyperglycemic hormone
- C. It causes increased strength of heart contraction
- D. It increases strength of heart contraction

Choose the correct answer from the options given below:

- (1) C and D only
- (2) B, C and D only
- (3) A, C and D only
- (4) D only

161. Why can't insulin be given orally to diabetic patients?

- (1) Human body will elicit strong immune response
- (2) It will be digested in gastro-intestinal (G) tract
- (3) Because of structural variation
- (4) Its bioavailability will be increased

162. Match List I with List II.

- | List I | List II |
|-----------------|------------------|
| A. Pteridophyte | I. Salvia |
| B. Bryophyte | II. Ginkgo |
| C. Angiosperm | III. Polytrichum |
| D. Gymnosperm | IV. Salvinia |

Choose the option with all correct matches.

- (1) A-III, B-IV, C-II, D-I
- (2) A-IV, B-III, C-I, D-II
- (3) A-III, B-IV, C-I, D-II
- (4) A-IV, B-III, C-II, D-I

163. Who proposed that the genetic code for amino acids should be made up of three nucleotides?

- (1) George gamow
- (2) Francis crick
- (3) Jacque monod
- (4) Franklin stahl

164. Match List I with List II:

List I	List II
A. The evil quartet	I. Cryopreservation
B. Ex situ conservation	II. Alien species invasion
C. Lantana camera	III. Causes of biodiversity losses
D. Dodo	IV. Extinction

Choose the option with all correct matches.

- (1) A-III, B-II, C-I, D-IV
- (2) A-III, B-I, C-II, D-IV
- (3) A-III, B-IV, C-II, D-I
- (4) A-III, B-II, C-IV, D-I

165. Which of the following hormones released from the pituitary is actually synthesized in the pituitary?

- (1) Luteinizing hormone (LH)
- (2) Anti-diuretic hormone (ADH)

- (3) Follicle-stimulating hormone (FSH)
- (4) Adrenocorticotrophic hormone (ACTH)

166. Role of the water vascular system in echinoderms is:

- A. Respiration and locomotion
- B. Excretion and locomotion
- C. Capture and transport of food
- D. Digestion and respiration
- E. Digestion and excretion

Choose the correct answer from the options given below:

- (1) A and B only
- (2) A and C only
- (3) B and C only
- (4) B, D and E only

167. Which of the following type of immunity is present at the time of birth and is a non-specific type of defence in the human body?

- (1) Acquired immunity
- (2) Innate immunity
- (3) Cell-mediated immunity
- (4) Humoral immunity

168. In bryophytes, the gametophytes help in which one of the following?

- (1) Sexual reproduction
- (2) Asexual reproduction
- (3) Nutrient absorption
- (4) Gaseous exchange

169. In frog, the renal portal system is a special venous connection that acts to link:

- (1) Liver and intestine
- (2) Liver and kidney
- (3) Kidney and intestine
- (4) Kidney and lower part of body

170. Given below are two statements:

Statement I: In ecosystem, there is unidirectional flow of energy of sun from producers to consumers.

Statement II: Ecosystems are exempted from 2nd law of thermodynamics.

In the light of the above statements, choose the most appropriate answer from the options given below:

- (1) Both statement I and statement II are correct
- (2) Both statement I and statement II are incorrect
- (3) Statement I is correct but statement II is incorrect
- (4) Statement I is incorrect but statement II is correct

171. Which of the following statements about rubisco is true?

- (1) It is active only in the dark
- (2) It has higher affinity for oxygen than carbon dioxide
- (3) It is an enzyme involved in the photosynthesis of water
- (4) It catalyzes the carboxylation of RuBP.

172. Which of the following enzyme(s) are not essential for gene cloning?

- A. Restriction enzymes
- B. DNA ligase
- C. DNA mutase
- D. DNA recombinase
- E. DNA polymerase

Choose the correct answer from the options given below:

- (1) C and D only
- (2) A and B only
- (3) D and E only
- (4) B and C only

173. Read the following statements on plant growth and development:

- A. Parthenocarpy can be induced by auxins
- B. Plant growth regulators can be involved in promotion as well as inhibition of growth
- C. De-differentiation is a pre-requisite for re-differentiation
- D. Abscisic acid is a plant growth promoter
- E. Apical dominance promotes the growth of lateral buds

Choose the option with all correct statements:

- (1) A, B, C only
- (2) A, C, E only
- (3) A, D, E only
- (4) B, D, E only

174. Which factor is important for termination of transcription?

- (1) α (alpha)
- (2) σ (sigma)
- (3) ρ (rho)
- (4) γ (gamma)

175. Frogs respire in water by skin and buccal cavity and on land by skin, buccal cavity and lungs.

Choose the correct answer from the following:

- (1) The statement is true for water but false for land

- (2) The statement is true for both the environment
- (3) The statement is false for water but true for land
- (4) The statement is false for both the environment

176. Twins are born to a family that lives next door to you. The twins are a boy and a girl. Which of the following must be true?

- (1) They are monozygotic twins
- (2) They are fraternal twins
- (3) They were conceived through in vitro fertilization
- (4) They have 75% identical genetic content

177. Which of the following microbes is not involved in the preparation of household products?

- A. *Aspergillus niger*
- B. *Lactobacillus*
- C. *Trichoderma polysporum*
- D. *Saccharomyces cerevisiae*
- E. *Propionibacterium sharmanii*

Choose the correct answer from the options given below:

- (1) A and B only
- (2) A and C only
- (3) C and D only
- (4) C and E only

178. Match List - I with List - II.

List - I	List - II
A. Progesterone	I. Pars intermedia
B. Relaxin	II. Ovary
C. Melanocyte stimulating hormone	III. Adrenal medulla
D. Catecholamines	IV. Corpus luteum

Choose the correct answer from the options given below:

- (1) A-IV, B-II, C-I, D-III
- (2) A-IV, B-II, C-III, D-I
- (3) A-II, B-IV, C-I, D-III
- (4) A-III, B-II, C-IV, D-I

179. The blue and white selectable markers have been developed which differentiates recombinant colonies from non-recombinant colonies on the basis of their ability to produce colour in the presence of a chromogenic substrate.

Given below are two statements about this method:

Statement I: the blue coloured colonies have dna insert in the plasmid and they are identified as recombinant colonies

Statement II: the colonies without blue colour have dna insert in the plasmid and are identified as recombinant colonies

In the light of the above statements, choose the most appropriate answer from the options given below:

- (1) Both statement I and statement II are correct
- (2) Both statement I and statement II are incorrect
- (3) Statement I is correct but statement II is incorrect
- (4) Statement I is incorrect but statement II is correct

180. Which one of the following equations represents the verhulst-pearl logistic growth of population?

- (1) $\frac{dN}{dt} = r \left(\frac{K-N}{K} \right)$
- (2) $\frac{dN}{dt} = rN \left(\frac{K-N}{K} \right)$
- (3) $\frac{dN}{dt} = rN \left(\frac{N-K}{N} \right)$
- (4) $\frac{dN}{dt} = N \left(\frac{r-K}{K} \right)$