

R1

This Booklet contains 28 pages.

Do not open this Test Booklet until you are asked to do so

Important Instructions :

- The Answer Sheet is inside this Test Booklet. When you are directed to open the Test Booklet, take out the Answer Sheet and fill in the particulars on ORIGINAL Copy carefully with blue/black ball point pen only. The test is of 3 hours 20 minutes duration and the Test Booklet contains 200 multiple-choice questions (four options with a single correct answer) from Physics, Chemistry and Biology (Botany and Zoology). 50 questions in each subject are divided into two Sections (A and B) as per details given below :
- Section A shall consist of 35 (Thirty-five) Questions in each subject (Question Nos - 1 to 35, 51 to 85, 101 to 135 and 151 to 185). All questions are compulsory.
 - Section B shall consist of 15 (Fifteen) questions in each subject (Question Nos - 36 to 50, 86 to 100, 136 to 150 and 186 to 200). In Section B, a candidate needs to attempt any 10 (Ten) questions out of 15 (Fifteen) in each subject.
- Candidates are advised to read all 15 questions in each subject of Section B before they start attempting the question paper. In the event of a candidate attempting more than ten questions, the first ten questions answered by the candidate shall be evaluated.
- Each question carries 4 marks. For each correct response, the candidate will get 4 marks. For each incorrect response, one mark will be deducted from the total scores. The maximum marks are 720.
 - Use Blue/Black Ball Point Pen only for writing particulars on this page/markings responses on Answer Sheet.
 - Rough work is to be done in the space provided for this purpose in the Test Booklet only.
 - On completion of the test, the candidate must hand over the Answer Sheet (ORIGINAL and OFFICE Copy) to the Invigilator before leaving the Room/Hall. The candidates are allowed to take away this Test Booklet with them.
 - The CODE for this Booklet is **R1**. Make sure that the CODE printed on the Original Copy of the Answer Sheet is the same as that on this Test Booklet. In case of discrepancy, the candidate should immediately report the matter to the Invigilator for replacement of both the Test Booklet and the Answer Sheet.
 - The candidates should ensure that the Answer Sheet is not folded. Do not make any stray marks on the Answer Sheet. Do not write your Roll No. anywhere else except in the specified space in the Test Booklet/ Answer Sheet.
 - Use of white fluid for correction is NOT permissible on the Answer Sheet.
 - Each candidate must show on-demand his/her Admit Card to the Invigilator.
 - No candidate, without special permission of the centre Superintendent or Invigilator, would leave his/her seat.
 - The candidates should not leave the Examination Hall without handing over their Answer Sheet to the Invigilator on duty and sign (with time) the Attendance Sheet twice. Cases, where a candidate has not signed the Attendance Sheet second time, will be deemed not to have handed over the Answer Sheet and dealt with as an Unfair Means case.
 - Use of Electronic/Manual Calculator is prohibited.
 - The candidates are governed by all Rules and Regulations of the examination with regard to their conduct in the Examination Room/Hall. All cases of unfair means will be dealt with as per the Rules and Regulations of this examination.
 - No part of the Test Booklet and Answer Sheet shall be detached under any circumstances.
 - The candidates will write the Correct Test Booklet Code as given in the Test Booklet/ Answer Sheet in the Attendance Sheet.
 - Compensatory time of one hour five minutes will be provided for the examination of three hours and 20 minutes duration, whether such candidate (having a physical limitation to write) uses the facility of scribe or not.

R1

Section - A (Physics)

1. In half wave rectification, if the input frequency is 60 Hz, then the output frequency would be :
- (1) 120 Hz
 - (2) zero
 - (3) 30 Hz
 - (4) 60 Hz

2. As the temperature increases, the electrical resistance :

- (1) decreases for conductors but increases for semiconductors
- (2) increases for both conductors and semiconductors
- (3) decreases for both conductors and semiconductors
- (4) increases for conductors but decreases for semiconductors

3. Let T_1 and T_2 be the energy of an electron in the first and second excited states of hydrogen atom, respectively. According to the Bohr's model of an atom, the ratio $T_1 : T_2$ is :

- (1) 9 : 4
- (2) 1 : 4
- (3) 4 : 1
- (4) 4 : 9

4. If a soap bubble expands, the pressure inside the bubble :

- (1) is equal to the atmospheric pressure
- (2) decreases
- (3) increases
- (4) remains the same

5. In the given nuclear reaction, the element X is :

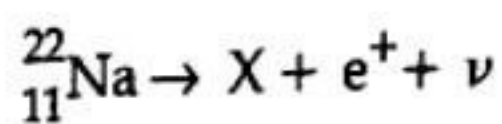

- (1) ${}_{12}^{22}\text{Mg}$
- (2) ${}_{11}^{23}\text{Na}$
- (3) ${}_{10}^{23}\text{Ne}$
- (4) ${}_{10}^{22}\text{Ne}$

2

6. A copper wire of length 10 m and radius $(10^{-2}/\sqrt{\pi})$ m has electrical resistance of 10Ω . The current density in the wire for an electric field strength of 10 (V/m) is :

- (1) 10^5 A/m^2
- (2) 10^4 A/m^2
- (3) 10^6 A/m^2
- (4) 10^{-5} A/m^2

7. The energy that will be ideally radiated by a 100 kW transmitter in 1 hour is :

- (1) $1 \times 10^5 \text{ J}$
- (2) $36 \times 10^7 \text{ J}$
- (3) $36 \times 10^4 \text{ J}$
- (4) $36 \times 10^5 \text{ J}$

8. Plane angle and solid angle have :

- (1) Both units and dimensions
- (2) Units but no dimensions
- (3) Dimensions but no units
- (4) No units and no dimensions

9. Two objects of mass 10 kg and 20 kg respectively are connected to the two ends of a rigid rod of length 10 m with negligible mass. The distance of the centre of mass of the system from the 10 kg mass is :

- (1) 5 m
- (2) $\frac{10}{3} \text{ m}$
- (3) $\frac{20}{3} \text{ m}$
- (4) 10 m

10. A spherical ball is dropped in a long column of highly viscous liquid. The curve in the graph shown, which represents the speed of the ball (v) as a function of time (t) is :

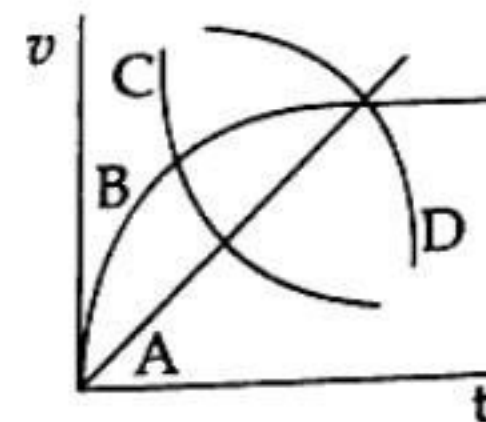

- (1) D
- (2) A
- (3) B
- (4) C

11. When light propagates through a material medium of relative permittivity ϵ_r and relative permeability μ_r , the velocity of light, v is given by : (c - velocity of light in vacuum)

(1) $v = \frac{c}{\sqrt{\epsilon_r \mu_r}}$

(2) $v = c$

(3) $v = \sqrt{\frac{\mu_r}{\epsilon_r}}$

(4) $v = \sqrt{\frac{\epsilon_r}{\mu_r}}$

12. The angular speed of a fly wheel moving with uniform angular acceleration changes from 1200 rpm to 3120 rpm in 16 seconds. The angular acceleration in rad/s^2 is :

(1) 104π

(2) 2π

(3) 4π

(4) 12π

13. Given below are two statements :

Statement I :

Biot-Savart's law gives us the expression for the magnetic field strength of an infinitesimal current element (Idl) of a current carrying conductor only.

Statement II :

Biot-Savart's law is analogous to Coulomb's inverse square law of charge q , with the former being related to the field produced by a scalar source, Idl while the latter being produced by a vector source, q .

In light of above statements choose the most appropriate answer from the options given below :

- (1) Statement I is incorrect and Statement II is correct
- (2) Both Statement I and Statement II are correct
- (3) Both Statement I and Statement II are incorrect
- (4) Statement I is correct and Statement II is incorrect

14. The dimensions $[MLT^{-2}A^{-2}]$ belong to the :

- (1) electric permittivity
- (2) magnetic flux
- (3) self inductance
- (4) magnetic permeability

15. In a Young's double slit experiment, a student observes 8 fringes in a certain segment of screen when a monochromatic light of 600 nm wavelength is used. If the wavelength of light is changed to 400 nm, then the number of fringes he would observe in the same region of the screen is :

(1) 12

(2) 6

(3) 8

(4) 9

16. The ratio of the radius of gyration of a thin uniform disc about an axis passing through its centre and normal to its plane to the radius of gyration of the disc about its diameter is :

(1) $1 : \sqrt{2}$

(2) $2 : 1$

(3) $\sqrt{2} : 1$

(4) $4 : 1$

17. A long solenoid of radius 1 mm has 100 turns per mm. If 1 A current flows in the solenoid, the magnetic field strength at the centre of the solenoid is :

(1) $6.28 \times 10^{-4} \text{ T}$

(2) $6.28 \times 10^{-2} \text{ T}$

(3) $12.56 \times 10^{-2} \text{ T}$

(4) $12.56 \times 10^{-4} \text{ T}$

18. An electric lift with a maximum load of 2000 kg (lift + passengers) is moving up with a constant speed of 1.5 ms^{-1} . The frictional force opposing the motion is 3000 N. The minimum power delivered by the motor to the lift in watts is : ($g = 10 \text{ ms}^{-2}$)

(1) 23500

(2) 23000

(3) 20000

(4) 34500

19. The peak voltage of the ac source is equal to :

(1) $1/\sqrt{2}$ times the rms value of the ac source

(2) the value of voltage supplied to the circuit

(3) the rms value of the ac source

(4) $\sqrt{2}$ times the rms value of the ac source

20. Two resistors of resistance, $100\ \Omega$ and $200\ \Omega$ are connected in parallel in an electrical circuit. The ratio of the thermal energy developed in $100\ \Omega$ to that in $200\ \Omega$ in a given time is :

- (1) 4 : 1
- (2) 1 : 2
- (3) 2 : 1
- (4) 1 : 4

21. A body of mass $60\ \text{g}$ experiences a gravitational force of $3.0\ \text{N}$, when placed at a particular point. The magnitude of the gravitational field intensity at that point is :

- (1) $180\ \text{N/kg}$
- (2) $0.05\ \text{N/kg}$
- (3) $50\ \text{N/kg}$
- (4) $20\ \text{N/kg}$

22. A light ray falls on a glass surface of refractive index $\sqrt{3}$, at an angle 60° . The angle between the refracted and reflected rays would be :

- (1) 120°
- (2) 30°
- (3) 60°
- (4) 90°

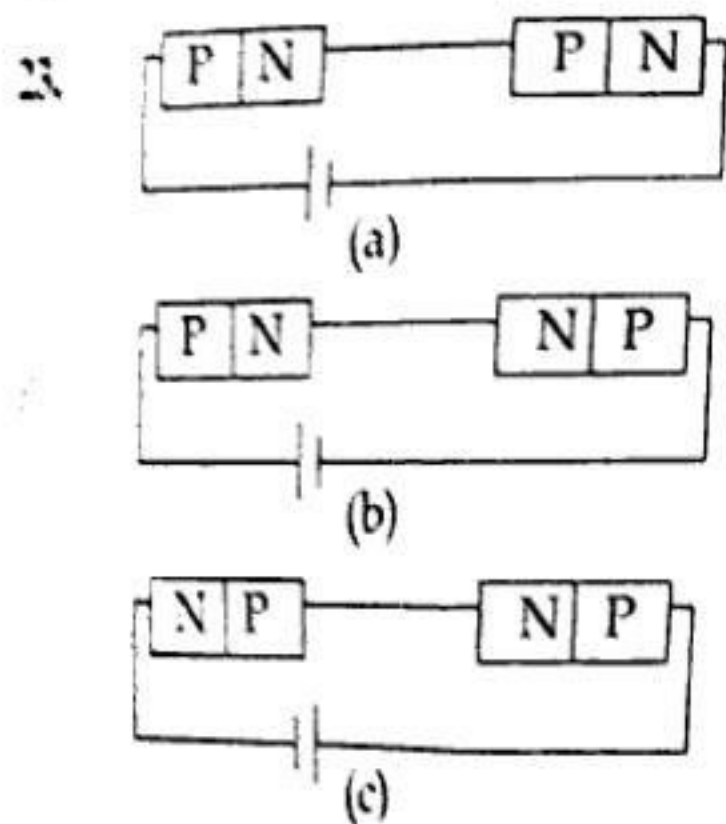

In the given circuits (a), (b) and (c), the potential drop across the two p-n junctions are equal in:

- (1) Both circuits (a) and (c)
- (2) Circuit (a) only
- (3) Circuit (b) only
- (4) Circuit (c) only

24. An ideal gas undergoes four different processes from the same initial state as shown in the figure below. Those processes are adiabatic, isothermal, isobaric and isochoric. The curve which represents the adiabatic process among 1, 2, 3 and 4 is :

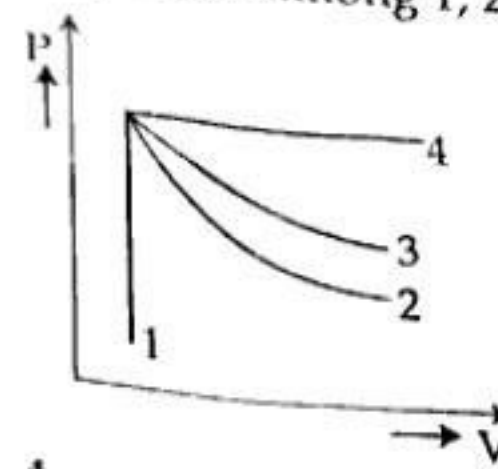

- (1) 4
- (2) 1
- (3) 2
- (4) 3

25. The angle between the electric lines of force and the equipotential surface is :

- (1) 180°
- (2) 0°
- (3) 45°
- (4) 90°

26. The displacement-time graphs of two moving particles make angles of 30° and 45° with the x-axis as shown in the figure. The ratio of their respective velocity is :

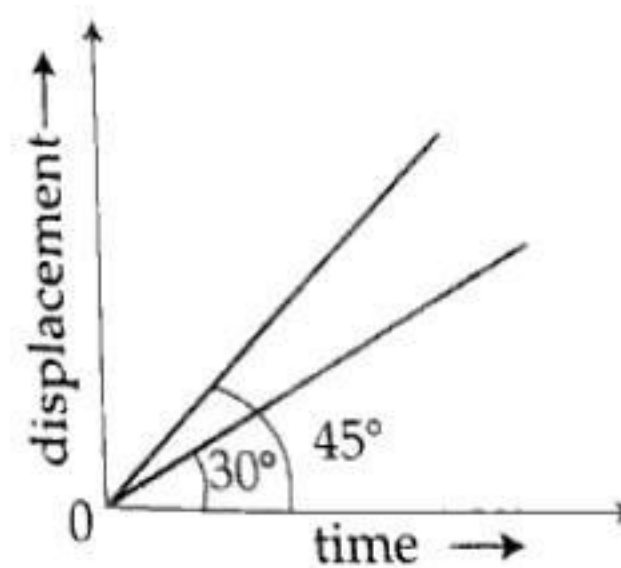

- (1) $1 : \sqrt{3}$
- (2) $\sqrt{3} : 1$
- (3) 1 : 1
- (4) 1 : 2

27. The ratio of the distances travelled by a freely falling body in the 1st, 2nd, 3rd and 4th second :

- (1) 1 : 1 : 1 : 1
- (2) 1 : 2 : 3 : 4
- (3) 1 : 4 : 9 : 16
- (4) 1 : 3 : 5 : 7

28. A shell of mass m is at rest initially. It explodes into three fragments having mass in the ratio 2 : 2 : 1. If the fragments having equal mass fly off along mutually perpendicular directions with speed v , the speed of the third (lighter) fragment is :

- (1) $3\sqrt{2} v$
- (2) v
- (3) $\sqrt{2} v$
- (4) $2\sqrt{2} v$

29. A biconvex lens has radii of curvature, 20 cm each. If the refractive index of the material of the lens is 1.5, the power of the lens is :

- (1) infinity
- (2) +2D
- (3) +20 D
- (4) +5D

30. The graph which shows the variation of the de Broglie wavelength (λ) of a particle and its associated momentum (p) is :

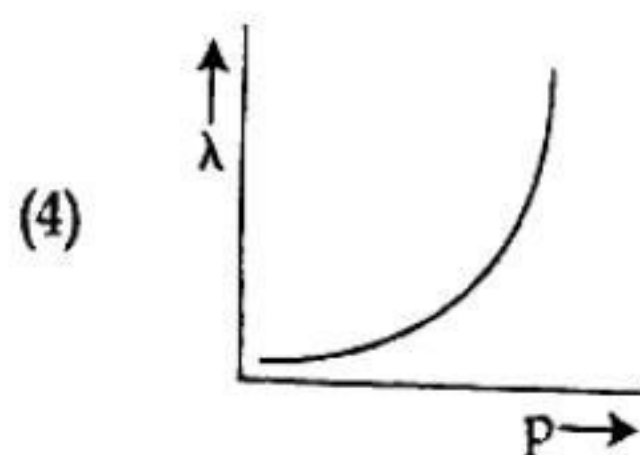
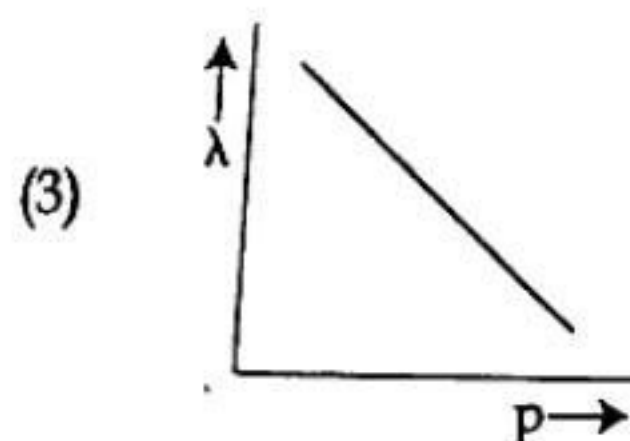
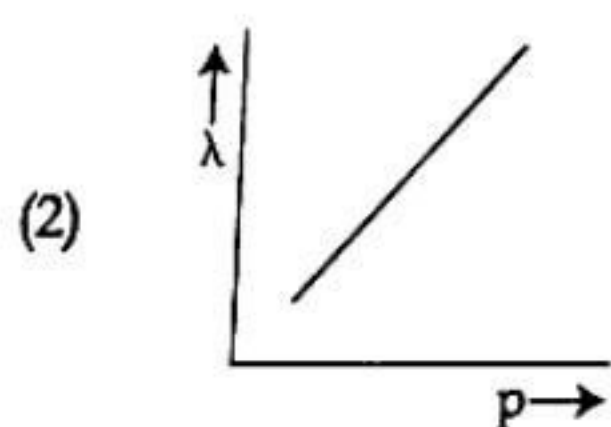

31.

When two monochromatic lights of frequency, ν and $\frac{\nu}{2}$ are incident on a photoelectric metal, their stopping potential becomes $\frac{V_s}{2}$ and V_s respectively. The threshold frequency for this metal is :

- (1) $\frac{3}{2}\nu$
- (2) 2ν
- (3) 3ν
- (4) $\frac{2}{3}\nu$

32.

Match List - I with List - II :

List - I	List - II
(Electromagnetic waves)	(Wavelength)
(a) AM radio waves	(i) 10^{-10} m
(b) Microwaves	(ii) 10^2 m
(c) Infrared radiations	(iii) 10^{-2} m
(d) X-rays	(iv) 10^{-4} m

Choose the correct answer from the options given below :

- (1) (a) - (ii), (b) - (iii), (c) - (iv), (d) - (i)
- (2) (a) - (iv), (b) - (iii), (c) - (ii), (d) - (i)
- (3) (a) - (iii), (b) - (ii), (c) - (i), (d) - (iv)
- (4) (a) - (iii), (b) - (iv), (c) - (ii), (d) - (i)

33.

A square loop of side 1 m and resistance 1Ω is placed in a magnetic field of 0.5 T. If the plane of loop is perpendicular to the direction of magnetic field, the magnetic flux through the loop is :

- (1) zero weber
- (2) 2 weber
- (3) 0.5 weber
- (4) 1 weber

34.

Two hollow conducting spheres of radii R_1 and R_2 ($R_1 \gg R_2$) have equal charges. The potential would be :

- (1) dependent on the material property of the sphere
- (2) more on bigger sphere
- (3) more on smaller sphere
- (4) equal on both the spheres

35.

If the initial tension on a stretched string is doubled, then the ratio of the initial and final speeds of transverse wave along the string is :

- (1) 1 : 2
- (2) 1 : 1
- (3) $\sqrt{2} : 1$
- (4) $1 : \sqrt{2}$

Section - B (Physics)

36. Two pendulums of length 121 cm and 100 cm start vibrating in phase. At some instant, the two are at their mean position in the same phase. The minimum number of vibrations of the shorter pendulum after which the two are again in phase at the mean position is :

- (1) 8
- (2) 11
- (3) 9
- (4) 10

37. A series LCR circuit with inductance 10 H, capacitance 10 μ F, resistance 50 Ω is connected to an ac source of voltage, $V = 200 \sin(100t)$ volt. If the resonant frequency of the LCR circuit is ν_0 and the frequency of the ac source is ν , then :

- (1) $\nu = 100 \text{ Hz} ; \nu_0 = \frac{100}{\pi} \text{ Hz}$
- (2) $\nu_0 = \nu = 50 \text{ Hz}$
- (3) $\nu_0 = \nu = \frac{50}{\pi} \text{ Hz}$
- (4) $\nu_0 = \frac{50}{\pi} \text{ Hz}, \nu = 50 \text{ Hz}$

38. A big circular coil of 1000 turns and average radius 10 m is rotating about its horizontal diameter at 2 rad s^{-1} . If the vertical component of earth's magnetic field at that place is $2 \times 10^{-5} \text{ T}$ and electrical resistance of the coil is 12.56 Ω , then the maximum induced current in the coil will be :

- (1) 2 A
- (2) 0.25 A
- (3) 1.5 A
- (4) 1 A

39. Two point charges $-q$ and $+q$ are placed at a distance of L , as shown in the figure.

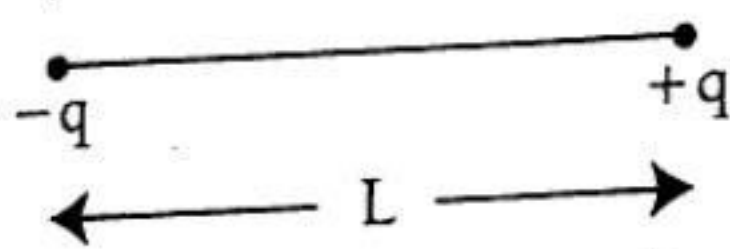

The magnitude of electric field intensity at a distance R ($R \gg L$) varies as :

- (1) $\frac{1}{R^6}$
- (2) $\frac{1}{R^2}$
- (3) $\frac{1}{R^3}$
- (4) $\frac{1}{R^4}$

40. From Ampere's circuital law for a long straight wire of circular cross-section carrying a steady current, the variation of magnetic field in the inside and outside region of the wire is :

- (1) a linearly decreasing function of distance upto the boundary of the wire and then a linearly increasing one for the outside region.
- (2) uniform and remains constant for both the regions.
- (3) a linearly increasing function of distance upto the boundary of the wire and then linearly decreasing for the outside region.
- (4) a linearly increasing function of distance r upto the boundary of the wire and then decreasing one with $1/r$ dependence for the outside region.

41. A wheatstone bridge is used to determine the value of unknown resistance X by adjusting the variable resistance Y as shown in the figure. For the most precise measurement of X , the resistances P and Q :

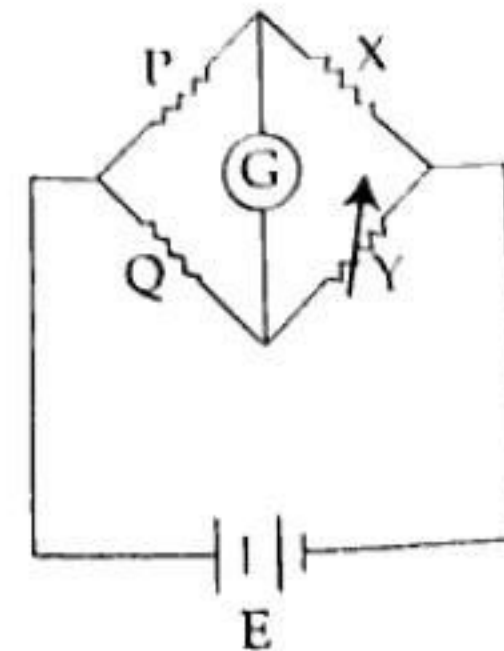

- (1) do not play any significant role
- (2) should be approximately equal to $2X$
- (3) should be approximately equal and are small
- (4) should be very large and unequal

42. A capacitor of capacitance $C = 900 \text{ pF}$ is charged fully by 100 V battery B as shown in figure (a). Then it is disconnected from the battery and connected to another uncharged capacitor of capacitance $C = 900 \text{ pF}$ as shown in figure (b). The electrostatic energy stored by the system (b) is :

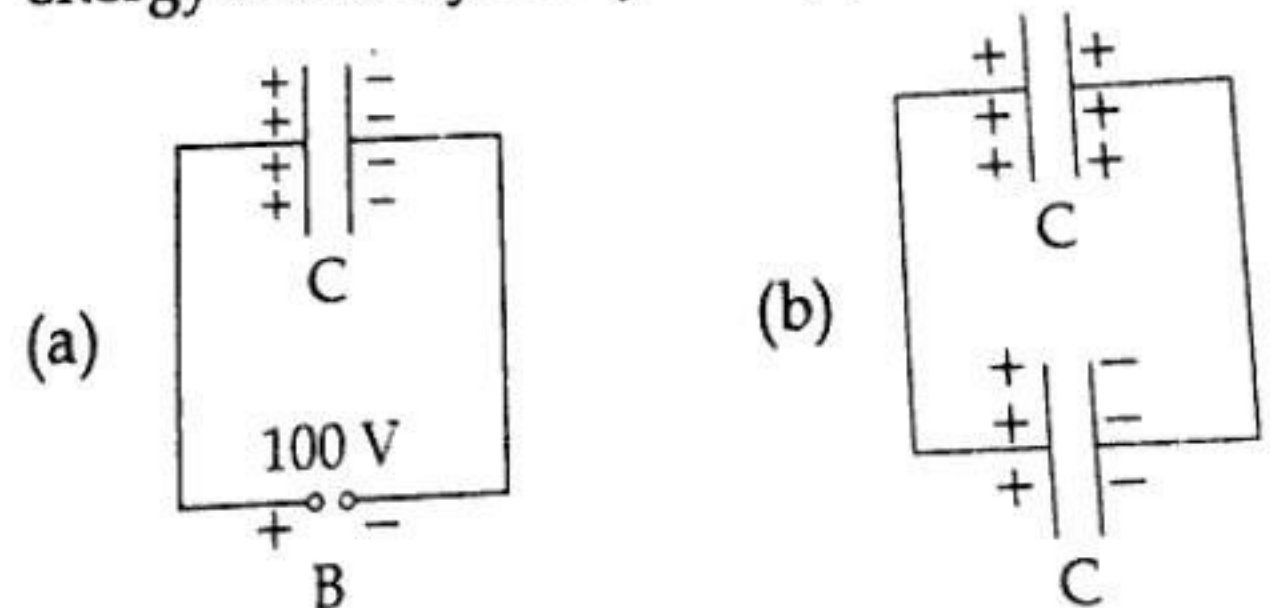

- (1) $1.5 \times 10^{-6} \text{ J}$
- (2) $4.5 \times 10^{-6} \text{ J}$
- (3) $3.25 \times 10^{-6} \text{ J}$
- (4) $2.25 \times 10^{-6} \text{ J}$

43. A nucleus of mass number 189 splits into two nuclei having mass number 125 and 64. The ratio of radius of two daughter nuclei respectively is :

- (1) 25 : 16
- (2) 1 : 1
- (3) 4 : 5
- (4) 5 : 4

44. The volume occupied by the molecules contained in 4.5 kg water at STP, if the intermolecular forces vanish away is :

- (1) 5.6 m^3
- (2) $5.6 \times 10^6 \text{ m}^3$
- (3) $5.6 \times 10^3 \text{ m}^3$
- (4) $5.6 \times 10^{-3} \text{ m}^3$

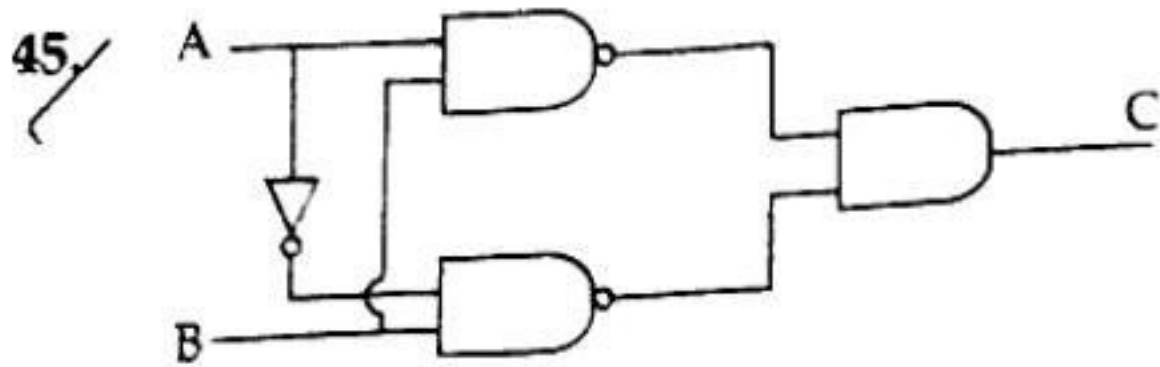

The truth table for the given logic circuit is :

(1)

A	B	C
0	0	0
0	1	1
1	0	0
1	1	1

(2)

A	B	C
0	0	0
0	1	1
1	0	1
1	1	0

(3)

A	B	C
0	0	1
0	1	0
1	0	0
1	1	1

(4)

A	B	C
0	0	1
0	1	0
1	0	1
1	1	0

46. A ball is projected with a velocity, 10 ms^{-1} , at an angle of 60° with the vertical direction. Its speed at the highest point of its trajectory will be :

- (1) 10 ms^{-1}
- (2) Zero
- (3) $5\sqrt{3} \text{ ms}^{-1}$
- (4) 5 ms^{-1}

47. Two transparent media A and B are separated by a plane boundary. The speed of light in those media are $1.5 \times 10^8 \text{ m/s}$ and $2.0 \times 10^8 \text{ m/s}$, respectively. The critical angle for a ray of light for these two media is :

- (1) $\tan^{-1}(0.750)$
- (2) $\sin^{-1}(0.500)$
- (3) $\sin^{-1}(0.750)$
- (4) $\tan^{-1}(0.500)$

48. Given below are two statements : One is labelled as Assertion (A) and the other is labelled as Reason (R).

Assertion (A) :

The stretching of a spring is determined by the shear modulus of the material of the spring.

Reason (R) :

A coil spring of copper has more tensile strength than a steel spring of same dimensions.

In the light of the above statements, choose the most appropriate answer from the options given below :

- (1) (A) is false but (R) is true
- (2) Both (A) and (R) are true and (R) is the correct explanation of (A)
- (3) Both (A) and (R) are true and (R) is not the correct explanation of (A)
- (4) (A) is true but (R) is false

49. Match List - I with List - II :

List - I	List - II
(a) Gravitational constant (G)	(i) $[L^2T^{-2}]$
(b) Gravitational potential energy	(ii) $[M^{-1}L^3T^{-2}]$
(c) Gravitational potential	(iii) $[LT^{-2}]$
(d) Gravitational intensity	(iv) $[ML^2T^{-2}]$

Choose the correct answer from the options given below :

- (1) (a) - (iv), (b) - (ii), (c) - (i), (d) - (iii)
- (2) (a) - (ii), (b) - (i), (c) - (iv), (d) - (iii)
- (3) (a) - (ii), (b) - (iv), (c) - (i), (d) - (iii)
- (4) (a) - (ii), (b) - (iv), (c) - (iii), (d) - (i)

50. The area of a rectangular field (in m^2) of length 55.3 m and breadth 25 m after rounding off the value for correct significant digits is :

- (1) 14×10^2
- (2) 138×10^1
- (3) 1382
- (4) 1382.5

51. The IUPAC name of an element with atomic number 119 is

- (1) ununoctium
- (2) ununennium
- (3) unnilennium
- (4) unununnium

52. The incorrect statement regarding enzymes is :

- (1) Enzymes are very specific for a particular reaction and substrate.
- (2) Enzymes are biocatalysts.
- (3) Like chemical catalysts enzymes reduce the activation energy of bio processes.
- (4) Enzymes are polysaccharides.

53. Given below are half cell reactions :

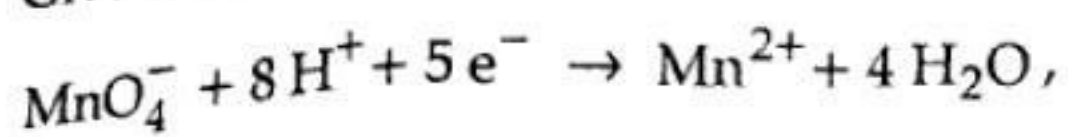

$$E_{\text{Mn}^{2+}/\text{MnO}_4^-}^\circ = -1.510 \text{ V}$$

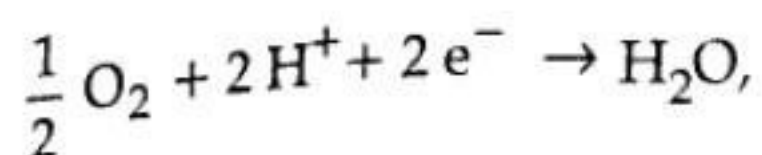

$$E_{\text{O}_2/\text{H}_2\text{O}}^\circ = +1.223 \text{ V}$$

Will the permanganate ion, MnO_4^- liberate O_2 from water in the presence of an acid ?

- (1) No, because $E_{\text{cell}}^\circ = -2.733 \text{ V}$
- (2) Yes, because $E_{\text{cell}}^\circ = +0.287 \text{ V}$
- (3) No, because $E_{\text{cell}}^\circ = -0.287 \text{ V}$
- (4) Yes, because $E_{\text{cell}}^\circ = +2.733 \text{ V}$

54. Which compound amongst the following is not an aromatic compound ?

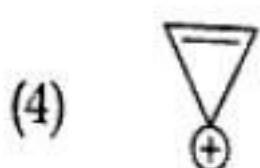
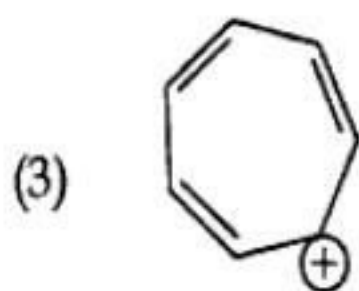
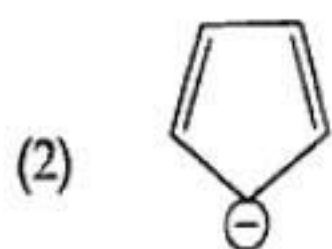
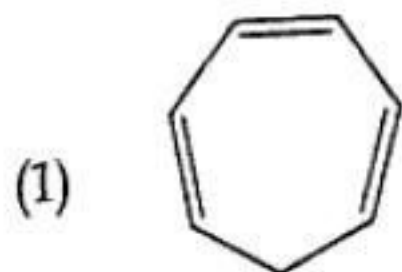

55.

The Kjeldahl's method for the estimation of nitrogen can be used to estimate the amount of nitrogen in which one of the following compounds ?

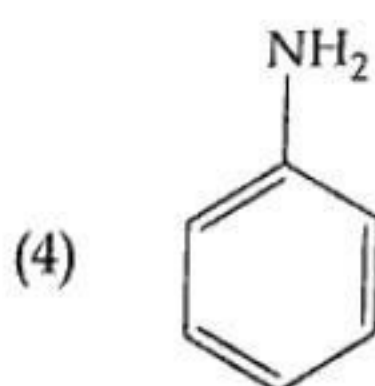
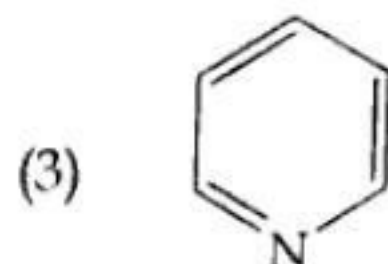
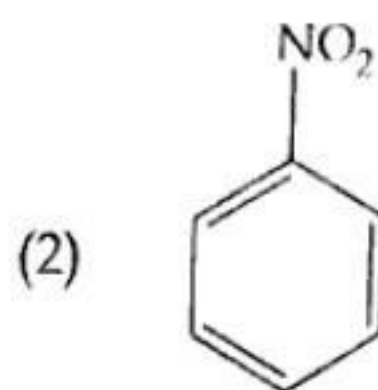
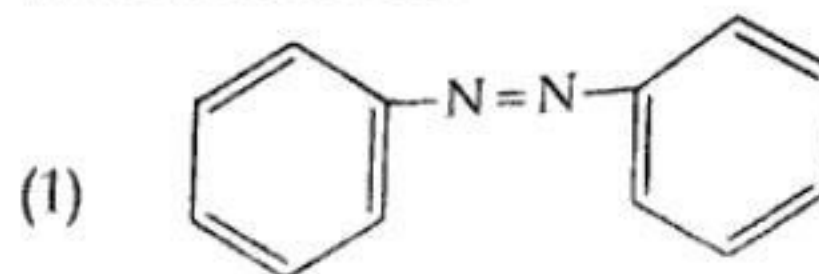

56. The pH of the solution containing 50 mL each of 0.10 M sodium acetate and 0.01 M acetic acid is [Given pK_a of $\text{CH}_3\text{COOH} = 4.57$]

- (1) 2.57
- (2) 5.57
- (3) 3.57
- (4) 4.57

57. Identify the incorrect statement from the following

- (1) Lithium is the strongest reducing agent among the alkali metals.
- (2) Alkali metals react with water to form their hydroxides.
- (3) The oxidation number of K in KO_2 is +4.
- (4) Ionisation enthalpy of alkali metals decreases from top to bottom in the group.

58. The incorrect statement regarding chirality is :

- (1) A racemic mixture shows zero optical rotation.
- (2) $\text{S}_{\text{N}}1$ reaction yields 1 : 1 mixture of both enantiomers.
- (3) The product obtained by $\text{S}_{\text{N}}2$ reaction of haloalkane having chirality at the reactive site shows inversion of configuration.
- (4) Enantiomers are superimposable mirror images on each other.

59. Given below are two statements -

Statement I:

In the coagulation of a negative col, the flocculating power of the three given ions is in the order

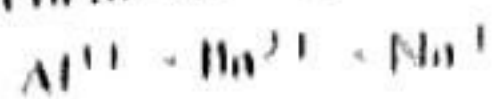

Statement II:

In the coagulation of a positive col, the flocculating power of the three given salts is in the order

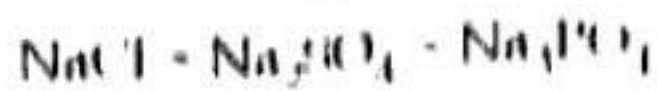

In the light of the above statements, choose the most appropriate answer from the options given below

- (1) Statement I is incorrect but Statement II is correct
- (2) Both Statement I and Statement II are correct
- (3) Both Statement I and Statement II are incorrect
- (4) Statement I is correct but Statement II is incorrect

60. Which one is not correct mathematical equation for Dalton's Law of partial pressure? Here p = total pressure of gaseous mixture

(1) $p_i = x_i p_i^0$, where x_i = mole fraction of i^{th} gas in gaseous mixture

p_i^0 = pressure of i^{th} gas in pure state

(2) $p = p_1 + p_2 + p_3$

(3) $p = n_1 \frac{RT}{V} + n_2 \frac{RT}{V} + n_3 \frac{RT}{V}$

(4) $p_i = x_i p$, where p_i = partial pressure of i^{th} gas

x_i = mole fraction of i^{th} gas in gaseous mixture

61. Which statement regarding polymers is not correct?

- (1) Thermosetting polymers are reusable.
- (2) Elastomers have polymer chains held together by weak intermolecular forces.
- (3) Fibers possess high tensile strength.
- (4) Thermoplastic polymers are capable of repeatedly softening and hardening on heating and cooling respectively.

62. Given below are two statements -

Statement I:

The boiling points of the following hydrocarbons in the order

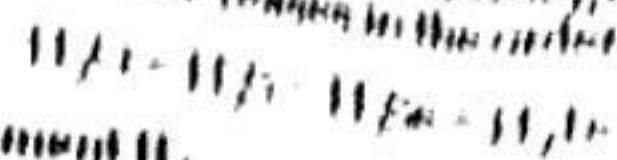

Statement II:

The boiling points of these hydrocarbons increase with increase in molar mass

In the light of the above statements, choose the most appropriate answer from the options given below

- (1) Statement I is incorrect but Statement II is correct
- (2) Both Statement I and Statement II are correct
- (3) Both Statement I and Statement II are incorrect
- (4) Statement I is correct but Statement II is incorrect

62. Given below are two statements

Statement I:

Primary aliphatic amines react with HNO_2 to give unstable diazonium salts

Statement II:

Primary aromatic amines react with HNO_2 to form diazonium salts which are stable even above $273K$.

In the light of the above statements, choose the most appropriate answer from the options given below

- (1) Statement I is incorrect but Statement II is correct.
- (2) Both Statement I and Statement II are correct.
- (3) Both Statement I and Statement II are incorrect.
- (4) Statement I is correct but Statement II is incorrect.

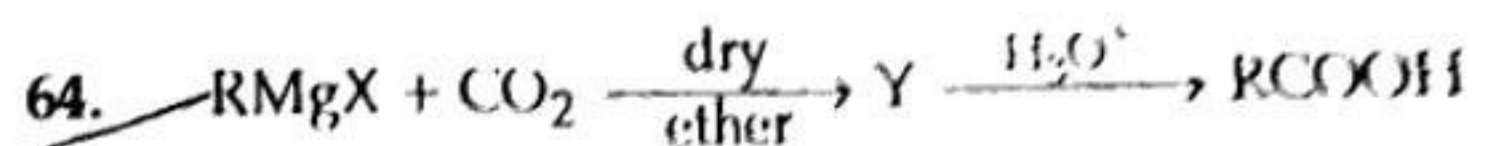

What is Y in the above reaction?

- (1) $(RCOO)_2Mg$
- (2) $RCOO^-Mg^+X$
- (3) $R_2CO^-Mg^+X$
- (4) $RCOO^-X^+$

R1

65. Given below are two statements: one is labelled as Assertion (A) and the other is labelled as Reason (R).

Assertion (A):

In a particular point defect, an ionic solid is electrically neutral, even if few of its cations are missing from its unit cells.

Reason (R):

In an ionic solid, Frenkel defect arises due to dislocation of cation from its lattice site to interstitial site, maintaining overall electrical neutrality.

In the light of the above statements, choose the most appropriate answer from the options given below:

- (1) (A) is not correct but (R) is correct
- (2) Both (A) and (R) are correct and (R) is the correct explanation of (A)
- (3) Both (A) and (R) are correct but (R) is not the correct explanation of (A)
- (4) (A) is correct but (R) is not correct

66. Match List - I with List - II.

List - I (Hydrides)	List - II (Nature)
(a) MgI_2	(i) Electron precise
(b) GeH_4	(ii) Electron deficient
(c) B_2H_6	(iii) Electron rich
(d) HF	(iv) Ionic

Choose the correct answer from the options given below:

- (1) (a) - (ii), (b) - (iii), (c) - (iv), (d) - (i)
- (2) (a) - (iv), (b) - (i), (c) - (ii), (d) - (iii)
- (3) (a) - (iii), (b) - (i), (c) - (ii), (d) - (iv)
- (4) (a) - (i), (b) - (ii), (c) - (iv), (d) - (iii)

67. Given below are two statements: one is labelled as Assertion (A) and the other is labelled as Reason (R).

Assertion (A): ICl is more reactive than I_2 .

Reason (R): I-Cl bond is weaker than I-I bond.

In the light of the above statements, choose the most appropriate answer from the options given below:

- (1) (A) is not correct but (R) is correct.
- (2) Both (A) and (R) are correct and (R) is the correct explanation of (A).
- (3) Both (A) and (R) are correct but (R) is not the correct explanation of (A).
- (4) (A) is correct but (R) is not correct.

68. Match List - I with List - II.

List - I	List - II
(a) I ₂	(i) absorbent for carbon dioxide
(b) Na	(ii) electrochemical cells
(c) KOH	(iii) coolant in fast breeder reactor
(d) C ₆₀	(iv) photoelectric cell

Choose the correct answer from the options given below:

- (1) (a) - (ii), (b) - (iii), (c) - (i), (d) - (iv)
- (2) (a) - (iv), (b) - (i), (c) - (iii), (d) - (ii)
- (3) (a) - (iii), (b) - (iv), (c) - (ii), (d) - (i)
- (4) (a) - (i), (b) - (iii), (c) - (iv), (d) - (ii)

69. Match List - I with List - II.

List - I (Drug class)	List - II (Drug molecule)
(a) Antacids	(i) Salvarsan
(b) Antihistamines	(ii) Morphine
(c) Analgesics	(iii) Cimetidine
(d) Antimicrobials	(iv) Seldane

Choose the correct answer from the options given below:

- (1) (a) - (iv), (b) - (iii), (c) - (i), (d) - (ii)
- (2) (a) - (iii), (b) - (ii), (c) - (iv), (d) - (i)
- (3) (a) - (iii), (b) - (iv), (c) - (ii), (d) - (i)
- (4) (a) - (i), (b) - (iv), (c) - (ii), (d) - (iii)

70. Identify the incorrect statement from the following.

- (1) The shapes of d_{xy} , d_{yz} , and d_{zx} orbitals are similar to each other; and $d_{x^2-y^2}$ and d_{z^2} are similar to each other.
- (2) All the five 5d orbitals are different in size when compared to the respective 4d orbitals.
- (3) All the five 4d orbitals have shapes similar to the respective 3d orbitals.
- (4) In an atom, all the five 3d orbitals are equal in energy in free state.

71. Choose the correct statement:

- (1) Both diamond and graphite are used as dry lubricants.
- (2) Diamond and graphite have two dimensional network.
- (3) Diamond is covalent and graphite is ionic.
- (4) Diamond is sp^3 hybridised and graphite sp^2 hybridized.

72. Which amongst the following is incorrect statement?

- (1) O_2^+ ion is diamagnetic.
- (2) The bond orders of O_2^+ , O_2 , O_2^- and O_2^{2-} are 2.5, 2, 1.5 and 1, respectively.
- (3) C_2 molecule has four electrons in its two degenerate π molecular orbitals.
- (4) H_2^+ ion has one electron.

73. In one molal solution that contains 0.5 mole of a solute, there is

- (1) 1000 g of solvent
- (2) 500 mL of solvent
- (3) 500 g of solvent
- (4) 100 mL of solvent

74. Given below are two statements :

Statement I :

The acidic strength of monosubstituted nitrophenol is higher than phenol because of electron withdrawing nitro group.

Statement II :

o-nitrophenol, *m*-nitrophenol and *p*-nitrophenol will have same acidic strength as they have one nitro group attached to the phenolic ring.

In the light of the above statements, choose the most appropriate answer from the options given below :

- (1) Statement I is incorrect but Statement II is correct.
- (2) Both Statement I and Statement II are correct.
- (3) Both Statement I and Statement II are incorrect.
- (4) Statement I is correct but Statement II is incorrect.

75. Which of the following p-V curve represents maximum work done? R1

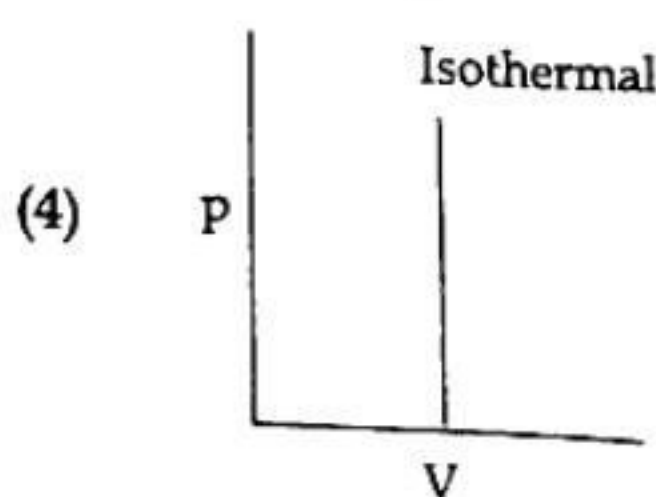
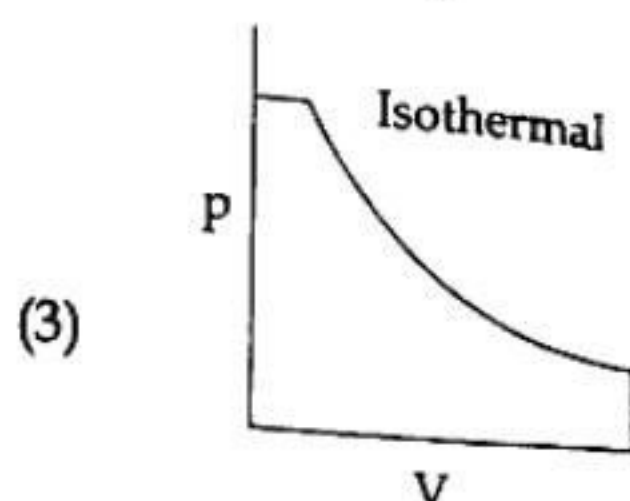
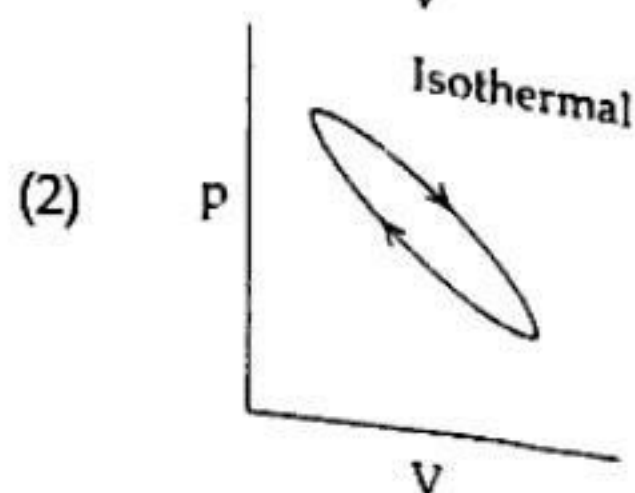
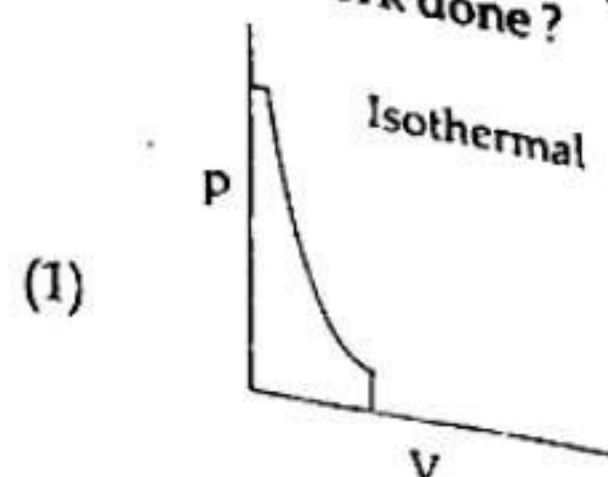

76. What mass of 95% pure $CaCO_3$ will be required to neutralise 50 mL of 0.5 M HCl solution according to the following reaction?

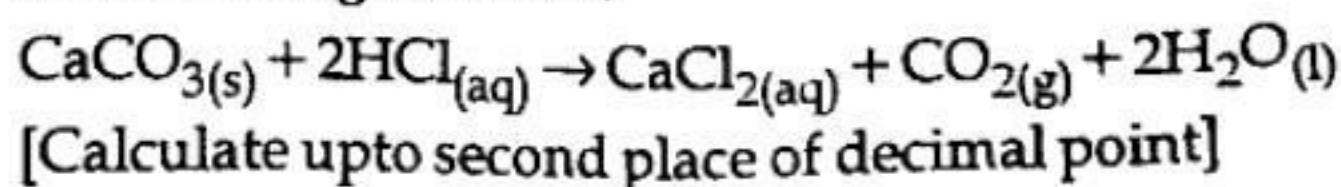

- (1) 9.50 g
- (2) 1.25 g
- (3) 1.32 g
- (4) 3.65 g

77. Which of the following is suitable to synthesize chlorobenzene?

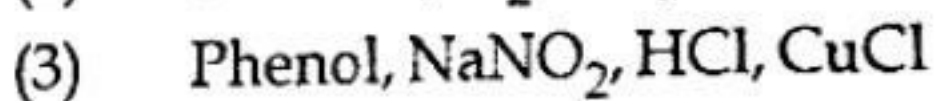
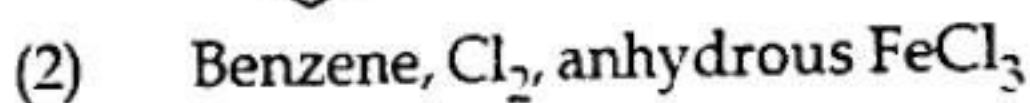
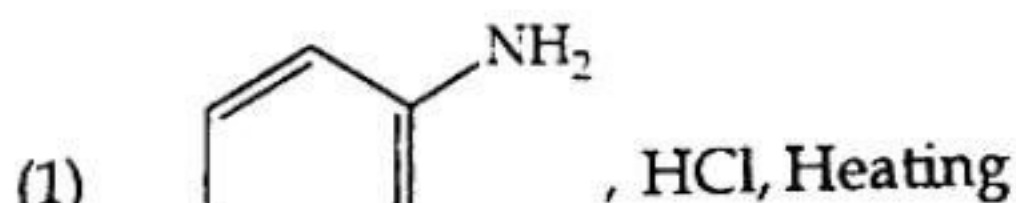

R1

78. Which of the following statement is not correct about diborane?

- (1) Both the Boron atoms are sp^2 hybridised.
- (2) There are two 3-centre-2-electron bonds.
- (3) The four terminal B-H bonds are two centre two electron bonds.
- (4) The four terminal Hydrogen atoms and the two Boron atoms lie in one plane.

79. Match List - I with List - II.

List - I
(Products formed)

List - II
(Reaction of carbonyl compound with)

- | | |
|-------------------|---------------|
| (a) Cyanohydrin | (i) NH_2OH |
| (b) Acetal | (ii) RNH_2 |
| (c) Schiff's base | (iii) alcohol |
| (d) Oxime | (iv) HCN |

Choose the correct answer from the options given below:

- (1) (a) - (iv), (b) - (iii), (c) - (ii), (d) - (i)
- (2) (a) - (iii), (b) - (iv), (c) - (ii), (d) - (i)
- (3) (a) - (ii), (b) - (iii), (c) - (iv), (d) - (i)
- (4) (a) - (i), (b) - (iii), (c) - (ii), (d) - (iv)

80. At 298 K, the standard electrode potentials of Cu^{2+}/Cu , Zn^{2+}/Zn , Fe^{2+}/Fe and Ag^+/Ag are 0.34 V, -0.76 V, -0.44 V and 0.80 V, respectively.

On the basis of standard electrode potential, predict which of the following reaction can not occur?

- (1) $2CuSO_4(aq) + 2Ag(s) \rightarrow 2Cu(s) + Ag_2SO_4(aq)$
- (2) $CuSO_4(aq) + Zn(s) \rightarrow ZnSO_4(aq) + Cu(s)$
- (3) $CuSO_4(aq) + Fe(s) \rightarrow FeSO_4(aq) + Cu(s)$
- (4) $FeSO_4(aq) + Zn(s) \rightarrow ZnSO_4(aq) + Fe(s)$

81. Given below are two statements:

Statement I:

The boiling points of aldehydes and ketones are higher than hydrocarbons of comparable molecular masses because of weak molecular association in aldehydes and ketones due to dipole - dipole interactions.

Statement II:

The boiling points of aldehydes and ketones are lower than the alcohols of similar molecular masses due to the absence of H-bonding.

In the light of the above statements, choose the most appropriate answer from the options given below:

- (1) Statement I is incorrect but Statement II is correct.
- (2) Both Statement I and Statement II are correct.
- (3) Both Statement I and Statement II are incorrect.
- (4) Statement I is correct but Statement II is incorrect.

82. Amongst the following which one will have maximum 'lone pair - lone pair' electron repulsions?

- (1) XeF_2
- (2) ClF_3
- (3) IF_5
- (4) SF_4

83. The IUPAC name of the complex - $[Ag(H_2O)_2][Ag(CN)_2]$ is:

- (1) diaquasilver(I) dicyanidoargentate(I)
- (2) dicyanidosilver(II) diaquaargentate(II)
- (3) diaquasilver(II) dicyanidoargentate(II)
- (4) dicyanidosilver(I) diaquaargentate(I)

84. Gadolinium has a low value of third ionisation enthalpy because of

- (1) high basic character
- (2) small size
- (3) high exchange enthalpy
- (4) high electronegativity

85. The given graph is a representation of kinetics of a reaction.

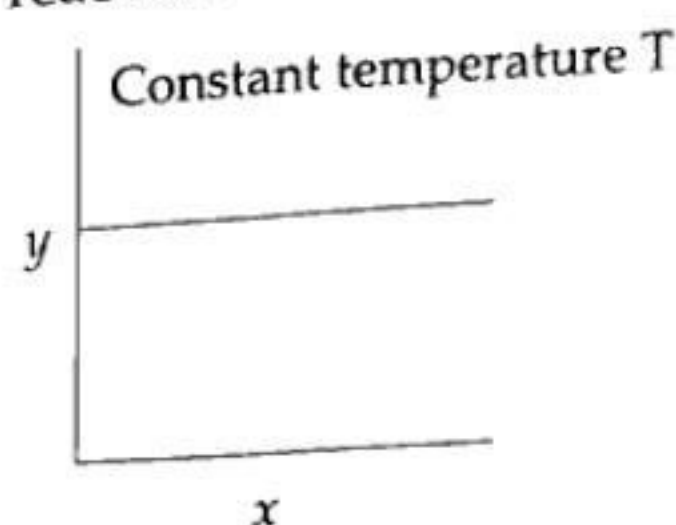

The y and x axes for zero and first order reactions, respectively are

- (1) zero order ($y = \text{rate}$ and $x = \text{concentration}$), first order ($y = \text{rate}$ and $x = t_{1/2}$)
- (2) zero order ($y = \text{concentration}$ and $x = \text{time}$), first order ($y = t_{1/2}$ and $x = \text{concentration}$)
- (3) zero order ($y = \text{concentration}$ and $x = \text{time}$), first order ($y = \text{rate constant}$ and $x = \text{concentration}$)
- (4) zero order ($y = \text{rate}$ and $x = \text{concentration}$), first order ($y = t_{1/2}$ and $x = \text{concentration}$)

Section - B (Chemistry)

86. If radius of second Bohr orbit of the He^+ ion is 105.8 pm, what is the radius of third Bohr orbit of Li^{2+} ion?

- (1) 158.7 Å
- (2) 158.7 pm
- (3) 15.87 pm
- (4) 1.587 pm

87. Find the emf of the cell in which the following reaction takes place at 298 K

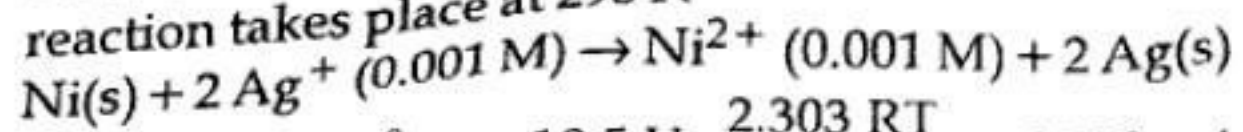

(Given that $E_{\text{cell}}^{\circ} = 1.05 \text{ V}$, $\frac{2.303 RT}{F} = 0.059$ at

298 K)

- (1) 1.05 V
- (2) 1.0385 V
- (3) 1.385 V
- (4) 0.9615 V

88. Match List - I with List - II.

List - I (Ores)		List - II (Composition)	
(a)	Haematite	(i)	Fe_3O_4
(b)	Magnetite	(ii)	ZnCO_3
(c)	Calamine	(iii)	Fe_2O_3
(d)	Kaolinite	(iv)	$[\text{Al}_2(\text{OH})_4\text{Si}_2\text{O}_5]$

Choose the correct answer from the options given below:

- (1) (a) - (i), (b) - (iii), (c) - (ii), (d) - (iv)
- (2) (a) - (i), (b) - (ii), (c) - (iii), (d) - (iv)
- (3) (a) - (iii), (b) - (i), (c) - (ii), (d) - (iv)
- (4) (a) - (iii), (b) - (i), (c) - (iv), (d) - (ii)

89. The correct IUPAC name of the following compound is:

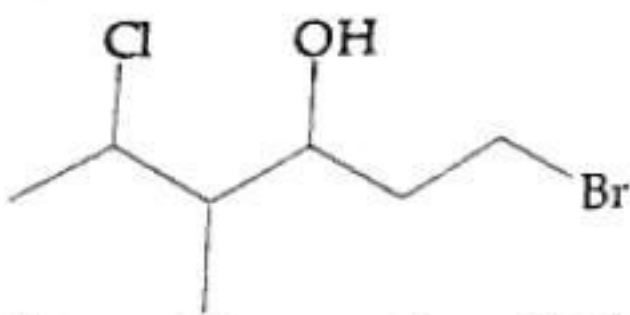

- (1) 6-bromo-4-methyl-2-chlorohexan-4-ol
- (2) 1-bromo-5-chloro-4-methylhexan-3-ol
- (3) 6-bromo-2-chloro-4-methylhexan-4-ol
- (4) 1-bromo-4-methyl-5-chlorohexan-3-ol

90. Which one of the following is not formed when acetone reacts with 2-pentanone in the presence of dilute NaOH followed by heating?

- (1)
- (2)
- (3)
- (4)

91. Compound X on reaction with O_3 followed by $\text{Zn}/\text{H}_2\text{O}$ gives formaldehyde and 2-methyl propanal as products. The compound X is:

- (1) Pent-2-ene
- (2) 3-Methylbut-1-ene
- (3) 2-Methylbut-1-ene
- (4) 2-Methylbut-2-ene

92. For a first order reaction $\text{A} \rightarrow \text{Products}$, initial concentration of A is 0.1 M, which becomes 0.001 M after 5 minutes. Rate constant for the reaction in min^{-1} is

- (1) 0.2303
- (2) 1.3818
- (3) 0.9212
- (4) 0.4606

93. $3 \text{O}_2(\text{g}) \rightleftharpoons 2 \text{O}_3(\text{g})$ for the above reaction at 298 K, K_c is found to be 3.0×10^{-59} . If the concentration of O_2 at equilibrium is 0.040 M then concentration of O_3 in M is

- (1) 1.2×10^{21}
- (2) 4.38×10^{-32}
- (3) 1.9×10^{-63}
- (4) 2.4×10^{31}

94. The pollution due to oxides of sulphur gets enhanced due to the presence of:

- (a) particulate matter
- (b) ozone
- (c) hydrocarbons
- (d) hydrogen peroxide

Choose the most appropriate answer from the options given below:

- (1) (a), (c), (d) only
- (2) (a), (d) only
- (3) (a), (b), (d) only
- (4) (b), (c), (d) only

95. The product formed from the following reaction sequence is

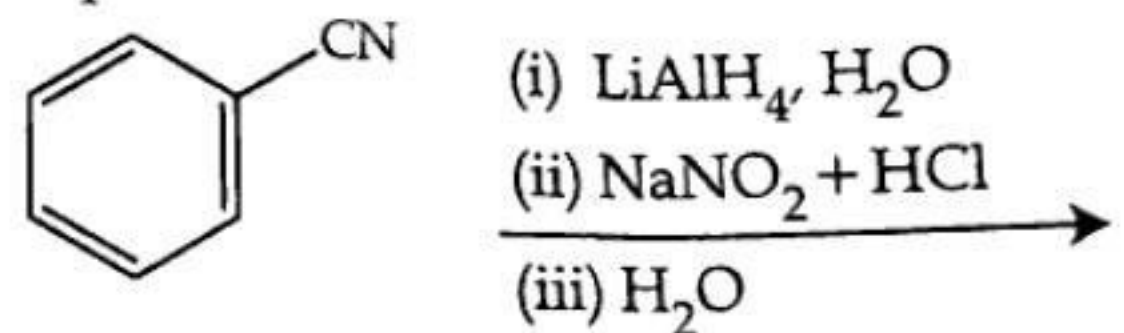

- (1)
- (2)
- (3)
- (4)

R1

96. In the neutral or faintly alkaline medium, KMnO_4 oxidises iodide into iodate. The change in oxidation state of manganese in this reaction is from

- (1) +6 to +5
- (2) +7 to +4
- (3) +6 to +4
- (4) +7 to +3

97. Given below are two statements :

Statement I:

In Lucas test, primary, secondary and tertiary alcohols are distinguished on the basis of their reactivity with conc. $\text{HCl} + \text{ZnCl}_2$, known as Lucas Reagent.

Statement II:

Primary alcohols are most reactive and immediately produce turbidity at room temperature on reaction with Lucas Reagent.

In the light of the above statements, choose the most appropriate answer from the options given below :

- (1) Statement I is incorrect but Statement II is correct.
- (2) Both Statement I and Statement II are correct.
- (3) Both Statement I and Statement II are incorrect.
- (4) Statement I is correct but Statement II is incorrect.

98. The order of energy absorbed which is responsible for the color of complexes

- (A) $[\text{Ni}(\text{H}_2\text{O})_2(\text{en})_2]^{2+}$
- (B) $[\text{Ni}(\text{H}_2\text{O})_4(\text{en})]^{2+}$ and
- (C) $[\text{Ni}(\text{en})_3]^{2+}$

is

- (1) (B) > (A) > (C)
- (2) (A) > (B) > (C)
- (3) (C) > (B) > (A)
- (4) (C) > (A) > (B)

99. A 10.0 L flask contains 64 g of oxygen at 27°C . (Assume O_2 gas is behaving ideally). The pressure inside the flask in bar is

(Given $R = 0.0831 \text{ L bar K}^{-1} \text{ mol}^{-1}$)

- (1) 4.9
- (2) 2.5
- (3) 498.6
- (4) 49.8

100. Copper crystallises in fcc unit cell with cell edge length of $3.608 \times 10^{-8} \text{ cm}$. The density of copper is 8.92 g cm^{-3} . Calculate the atomic mass of copper.

- (1) 65 u
- (2) 63.1 u
- (3) 31.55 u
- (4) 60 u

Section - A (Biology : Botany)

101. Which of the following is not a method of *ex situ* conservation ?

- (1) Cryopreservation
- (2) *In vitro* fertilization
- (3) National Parks
- (4) Micropropagation

102. Which one of the following statement is not true regarding gel electrophoresis technique ?

- (1) Bright orange coloured bands of DNA can be observed in the gel when exposed to UV light.
- (2) The process of extraction of separated DNA strands from gel is called elution.
- (3) The separated DNA fragments are stained by using ethidium bromide.
- (4) The presence of chromogenic substrate gives blue coloured DNA bands on the gel.

103. Which one of the following statements cannot be connected to Predation ?

- (1) It is necessitated by nature to maintain the ecological balance
- (2) It helps in maintaining species diversity in a community
- (3) It might lead to extinction of a species
- (4) Both the interacting species are negatively impacted

104. Which of the following is incorrectly matched ?

- (1) *Volvox* - Starch
- (2) *Ectocarpus* - Fucoxanthin
- (3) *Ulothrix* - Mannitol
- (4) *Porphyra* - Floridian Starch

105. Which one of the following plants does not show plasticity ?

- (1) Maize
- (2) Cotton
- (3) Coriander
- (4) Buttercup

106. XO type of sex determination can be found in :

- (1) Monkeys
- (2) *Drosophila*
- (3) Birds
- (4) Grasshoppers

107. The device which can remove particulate matter present in the exhaust from a thermal power plant is :

- (1) Catalytic Converter
- (2) STP
- (3) Incinerator
- (4) Electrostatic Precipitator

108. Identify the correct set of statements :

- (a) The leaflets are modified into pointed hard thorns in *Citrus* and *Bougainvillea*
- (b) Axillary buds form slender and spirally coiled tendrils in cucumber and pumpkin
- (c) Stem is flattened and fleshy in *Opuntia* and modified to perform the function of leaves
- (d) *Rhizophora* shows vertically upward growing roots that help to get oxygen for respiration
- (e) Subaerially growing stems in grasses and strawberry help in vegetative propagation

Choose the correct answer from the options given below :

- (1) (a), (b), (d) and (e) Only
- (2) (b) and (c) Only
- (3) (a) and (d) Only
- (4) (b), (c), (d) and (e) Only

109. What is the net gain of ATP when each molecule of glucose is converted to two molecules of pyruvic acid ?

- (1) Eight
- (2) Four
- (3) Six
- (4) Two

110. What amount of energy is released from glucose during lactic acid fermentation ?

- (1) Less than 7%
- (2) Approximately 15%
- (3) More than 18%
- (4) About 10%

111. Given below are two statements : one is labelled as Assertion (A) and the other is labelled as Reason (R).

Assertion (A):

Polymerase chain reaction is used in DNA amplification

Reason (R):

The ampicillin resistant gene is used as a selectable marker to check transformation

In the light of the above statements, choose the correct answer from the options given below :

- (1) (A) is not correct but (R) is correct
- (2) Both (A) and (R) are correct and (R) is the correct explanation of (A)
- (3) Both (A) and (R) are correct but (R) is not the correct explanation of (A)
- (4) (A) is correct but (R) is not correct

112. In old trees the greater part of secondary xylem is dark brown and resistant to insect attack due to :

- (a) secretion of secondary metabolites and their deposition in the lumen of vessels.
- (b) deposition of organic compounds like tannins and resins in the central layers of stem.
- (c) deposition of suberin and aromatic substances in the outer layer of stem.
- (d) deposition of tannins, gum, resin and aromatic substances in the peripheral layers of stem.
- (e) presence of parenchyma cells, functionally active xylem elements and essential oils.

Choose the correct answer from the options given below :

- (1) (b) and (d) Only
- (2) (a) and (b) Only
- (3) (c) and (d) Only
- (4) (d) and (e) Only

113. DNA polymorphism forms the basis of :

- (1) Translation
- (2) Genetic mapping
- (3) DNA finger printing
- (4) Both genetic mapping and DNA finger printing

114. Identify the incorrect statement related to Pollination :

- (1) Moths and butterflies are the most dominant pollinating agents among insects
- (2) Pollination by water is quite rare in flowering plants
- (3) Pollination by wind is more common amongst abiotic pollination
- (4) Flowers produce foul odours to attract flies and beetles to get pollinated

R1

115. Production of Cucumber has increased manifold in recent years. Application of which of the following phytohormones has resulted in this increased yield as the hormone is known to produce female flowers in the plants :

- (1) Cytokinin
- (2) ABA
- (3) Gibberellin
- (4) Ethylene

116. The flowers are Zygomorphic in :

- (a) Mustard
- (b) Gulmohar
- (c) Cassia
- (d) Datura
- (e) Chilly

Choose the correct answer from the options given below :

- (1) (c), (d), (e) Only
- (2) (a), (b), (c) Only
- (3) (b), (c) Only
- (4) (d), (e) Only

117. Which one of the following never occurs during mitotic cell division ?

- (1) Coiling and condensation of the chromatids
- (2) Spindle fibres attach to kinetochores of chromosomes
- (3) Movement of centrioles towards opposite poles
- (4) Pairing of homologous chromosomes

118. Given below are two statements :

Statement I:

Cleistogamous flowers are invariably autogamous

Statement II:

Cleistogamy is disadvantageous as there is no chance for cross pollination

In the light of the above statements, choose the correct answer from the options given below :

- (1) Statement I is incorrect but Statement II is correct
- (2) Both Statement I and Statement II are correct
- (3) Both Statement I and Statement II are incorrect
- (4) Statement I is correct but Statement II is incorrect

16

119. Habitat loss and fragmentation, over exploitation, alien species invasion and co-extinction are causes for :

- (1) Natality
- (2) Population explosion
- (3) Competition
- (4) Biodiversity loss

120. Given below are two statements :

Statement I:

Decomposition is a process in which the detritus degraded into simpler substances by microbes.

Statement II:

Decomposition is faster if the detritus is rich in lign and chitin

In the light of the above statements, choose the correct answer from the options given below :

- (1) Statement I is incorrect but Statement II correct
- (2) Both Statement I and Statement II are correct
- (3) Both Statement I and Statement II are incorrect
- (4) Statement I is correct but Statement II incorrect

121.

Given below are two statements :

Statement I:

The primary CO_2 acceptor in C_4 plants phosphoenolpyruvate and is found in the mesophyll cells.

Statement II:

Mesophyll cells of C_4 plants lack RuBisCo enzyme

In the light of the above statements, choose the correct answer from the options given below :

- (1) Statement I is incorrect but Statement II correct
- (2) Both Statement I and Statement II are correct
- (3) Both Statement I and Statement II are incorrect
- (4) Statement I is correct but Statement II incorrect

122. Read the following statements and choose the set of correct statements :

- (a) Euchromatin is loosely packed chromatin
- (b) Heterochromatin is transcriptionally active
- (c) Histone octamer is wrapped by negatively charged DNA in nucleosome
- (d) Histones are rich in lysine and arginine
- (e) A typical nucleosome contains 400 bp of DNA helix

Choose the correct answer from the options given below :

- (1) (a), (c), (e) Only
- (2) (b), (d), (e) Only
- (3) (a), (c), (d) Only
- (4) (b), (e) Only

123. Read the following statements about the vascular bundles :

- (a) In roots, xylem and phloem in a vascular bundle are arranged in an alternate manner along the different radii.
- (b) Conjoint closed vascular bundles do not possess cambium
- (c) In open vascular bundles, cambium is present in between xylem and phloem
- (d) The vascular bundles of dicotyledonous stem possess endarch protoxylem
- (e) In monocotyledonous root, usually there are more than six xylem bundles present

Choose the correct answer from the options given below :

- (1) (a), (c), (d) and (e) Only
- (2) (a), (b) and (d) Only
- (3) (b), (c), (d) and (e) Only
- (4) (a), (b), (c) and (d) Only

124. "Girdling Experiment" was performed by Plant Physiologists to identify the plant tissue through which :

- (1) osmosis is observed
- (2) water is transported
- (3) food is transported
- (4) for both water and food transportation

125. Which one of the following is not true regarding the release of energy during ATP synthesis through chemiosmosis? It involves :

- (1) Reduction of NADP to NADPH₂ on the stroma side of the membrane
- (2) Breakdown of proton gradient
- (3) Breakdown of electron gradient
- (4) Movement of protons across the membrane to the stroma

126. Given below are two statements :

R1

Statement I :

Mendel studied seven pairs of contrasting traits in pea plants and proposed the Laws of Inheritance

Statement II :

Seven characters examined by Mendel in his experiment on pea plants were seed shape and colour, flower colour, pod shape and colour, flower position and stem height

In the light of the above statements, choose the correct answer from the options given below :

- (1) Statement I is incorrect but Statement II is correct
- (2) Both Statement I and Statement II are correct
- (3) Both Statement I and Statement II are incorrect
- (4) Statement I is correct but Statement II is incorrect

127. Match List - I with List - II.

List - I	List - II
(a) Manganese	(i) Activates the enzyme catalase
(b) Magnesium	(ii) Required for pollen germination
(c) Boron	(iii) Activates enzymes of respiration
(d) Iron	(iv) Functions in splitting of water during photosynthesis

Choose the correct answer from the options given below :

- (1) (a) - (iii), (b) - (i), (c) - (ii), (d) - (iv)
- (2) (a) - (iii), (b) - (iv), (c) - (i), (d) - (ii)
- (3) (a) - (iv), (b) - (iii), (c) - (ii), (d) - (i)
- (4) (a) - (iv), (b) - (i), (c) - (ii), (d) - (iii)

128. The appearance of recombination nodules on homologous chromosomes during meiosis characterizes :

- (1) Terminalization
- (2) Synaptonemal complex
- (3) Bivalent
- (4) Sites at which crossing over occurs

129. Which of the following is not observed during apoplastic pathway ?

- (1) Apoplast is continuous and does not provide any barrier to water movement.
- (2) Movement of water occurs through intercellular spaces and wall of the cells.
- (3) The movement does not involve crossing of cell membrane
- (4) The movement is aided by cytoplasmic streaming

130. The process of translation of mRNA to proteins begins as soon as :
- (1) The tRNA is activated and the larger subunit of ribosome encounters mRNA
 - (2) The small subunit of ribosome encounters mRNA
 - (3) The larger subunit of ribosome encounters mRNA
 - (4) Both the subunits join together to bind with mRNA
131. Which one of the following produces nitrogen fixing nodules on the roots of *Alnus* ?
- (1) *Beijernickia*
 - (2) *Rhizobium*
 - (3) *Frankia*
 - (4) *Rhodospirillum*
132. The gaseous plant growth regulator is used in plants to :
- (1) kill dicotyledonous weeds in the fields
 - (2) speed up the malting process
 - (3) promote root growth and root hair formation to increase the absorption surface
 - (4) help overcome apical dominance
133. Hydrocolloid carrageen is obtained from :
- (1) Phaeophyceae only
 - (2) Chlorophyceae and Phaeophyceae
 - (3) Phaeophyceae and Rhodophyceae
 - (4) Rhodophyceae only
134. Exoskeleton of arthropods is composed of :
- (1) Glucosamine
 - (2) Cutin
 - (3) Cellulose
 - (4) Chitin
135. Which one of the following plants shows vexillary aestivation and diadelphous stamens ?
- (1) *Solanum nigrum*
 - (2) *Colchicum autumnale*
 - (3) *Pisum sativum*
 - (4) *Allium cepa*

136. The entire fleet of buses in Delhi were converted CNG from diesel. In reference to this, which of the following statements is false ?

- (1) It can not be adulterated like diesel
- (2) CNG burns more efficiently than diesel
- (3) The same diesel engine is used in CNG making the cost of conversion low
- (4) It is cheaper than diesel

137. What is the role of large bundle sheath cells around the vascular bundles in C_4 plants ?

- (1) To protect the vascular tissue from high intensity
- (2) To provide the site for photorespiration pathway
- (3) To increase the number of chloroplasts for operation of Calvin cycle
- (4) To enable the plant to tolerate high temperature

138. Read the following statements on lipids and choose the correct set of statements :

- (a) Lecithin found in the plasma membrane is a glycolipid
- (b) Saturated fatty acids possess one or more $C=C$ bonds
- (c) Gingely oil has lower melting point and remains as oil in winter
- (d) Lipids are generally insoluble in water but soluble in some organic solvents
- (e) When fatty acid is esterified with glycerol, monoglycerides are formed

Choose the correct answer from the options given below :

- (1) (a), (b) and (d) only
- (2) (a), (b) and (c) only
- (3) (a), (d) and (e) only
- (4) (c), (d) and (e) only

139. Match List - I with List - II.

List - I	List - II
(a) Metacentric chromosome	(i) Centromere situated close to the end forming one extremely short and one very long arms
(b) Acrocentric chromosome	(ii) Centromere at the terminal end
(c) Sub-metacentric	(iii) Centromere in the middle forming two equal arms of chromosomes
(d) Telocentric chromosome	(iv) Centromere slightly away from the middle forming one shorter arm and one longer arm

Choose the correct answer from the options given below :

- (1) (a) - (i), (b) - (ii), (c) - (iii), (d) - (iv)
- (2) (a) - (iii), (b) - (i), (c) - (iv), (d) - (ii)
- (3) (a) - (i), (b) - (iii), (c) - (ii), (d) - (iv)
- (4) (a) - (ii), (b) - (iii), (c) - (iv), (d) - (i)

140. If a geneticist uses the blind approach for sequencing the whole genome of an organism, followed by assignment of function to different segments, the methodology adopted by him is called as :

- (1) Bioinformatics
- (2) Sequence annotation
- (3) Gene mapping
- (4) Expressed sequence tags

141. In the following palindromic base sequences of DNA, which one can be cut easily by particular restriction enzyme ?

- (1) 5' GTATTC3' ; 3' CATAAG5'
- (2) 5' GATACT3' ; 3' CTATGA5'
- (3) 5' GAATTC3' ; 3' CTTAAG5'
- (4) 5' CTCAGT3' ; 3' GAGTCA5'

142. While explaining interspecific interaction of population, (+) sign is assigned for beneficial interaction, (-) sign is assigned for detrimental interaction and (0) for neutral interaction. Which of the following interactions can be assigned (+) for one species and (-) for another species involved in the interaction ?

- (1) Competition
- (2) Predation
- (3) Amensalism
- (4) Commensalism

143. Which one of the following will accelerate phosphorus cycle? R1

- (1) Rain fall and storms
- (2) Burning of fossil fuels
- (3) Volcanic activity
- (4) Weathering of rocks

144. Which of the following occurs due to the presence of autosome linked dominant trait ?

- (1) Thalessemia
- (2) Sickle cell anaemia
- (3) Myotonic dystrophy
- (4) Haemophilia

145. The anatomy of springwood shows some peculiar features. Identify the correct set of statements about springwood.

- (a) It is also called as the earlywood
- (b) In spring season cambium produces xylem elements with narrow vessels
- (c) It is lighter in colour
- (d) The springwood along with autumnwood shows alternate concentric rings forming annual rings
- (e) It has lower density

Choose the correct answer from the options given below :

- (1) (c), (d) and (e) Only
- (2) (a), (b), (d) and (e) Only
- (3) (a), (c), (d) and (e) Only
- (4) (a), (b) and (d) Only

146. Given below are two statements : one is labelled as Assertion (A) and the other is labelled as Reason (R).

Assertion (A):

Mendel's law of Independent assortment does not hold good for the genes that are located closely on the same chromosome.

Reason (R):

Closely located genes assort independently.

In the light of the above statements, choose the correct answer from the options given below :

- (1) (A) is not correct but (R) is correct
- (2) Both (A) and (R) are correct and (R) is the correct explanation of (A)
- (3) Both (A) and (R) are correct but (R) is not the correct explanation of (A)
- (4) (A) is correct but (R) is not correct

R1

147. Transposons can be used during which one of the following?

- (1) Gene sequencing
- (2) Polymerase Chain Reaction
- (3) Gene silencing
- (4) Autoradiography

148. Match the plant with the kind of life cycle it exhibits:

List - I	List - II
(a) <i>Spirogyra</i>	(i) Dominant diploid sporophyte vascular plant, with highly reduced male or female gametophyte
(b) Fern	(ii) Dominant haploid free-living gametophyte
(c) <i>Funaria</i>	(iii) Dominant diploid sporophyte alternating with reduced gametophyte called prothallus
(d) <i>Cycas</i>	(iv) Dominant haploid leafy gametophyte alternating with partially dependent multicellular sporophyte

Choose the correct answer from the options given below:

- (1) (a) - (ii), (b) - (iv), (c) - (i), (d) - (iii)
- (2) (a) - (iv), (b) - (i), (c) - (ii), (d) - (iii)
- (3) (a) - (ii), (b) - (iii), (c) - (iv), (d) - (i)
- (4) (a) - (iii), (b) - (iv), (c) - (i), (d) - (ii)

149. Addition of more solutes in a given solution will:

- (1) not affect the water potential at all
- (2) raise its water potential
- (3) lower its water potential
- (4) make its water potential zero

150. Which part of the fruit, labelled in the given figure makes it a false fruit?

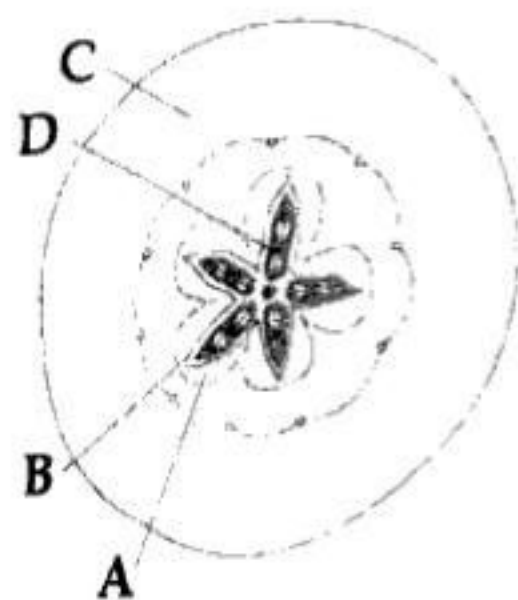

- (1) D → Seed
- (2) A → Mesocarp
- (3) B → Endocarp
- (4) C → Thalamus

20

Section - A (Biology : Zoology)

151. In the taxonomic categories which hierarchy arrangement in ascending order is correct in case of animals?

- (1) Kingdom, Order, Phylum, Class, Family, Genus, Species
- (2) Kingdom, Phylum, Class, Order, Family, Genus, Species
- (3) Kingdom, Class, Phylum, Family, Order, Genus, Species
- (4) Kingdom, Order, Class, Phylum, Family, Genus, Species

152. In gene therapy of Adenosine Deaminase (ADA) deficiency, the patient requires periodic infusion of genetically engineered lymphocytes because:

- (1) Genetically engineered lymphocytes are immortal cells.
- (2) Retroviral vector is introduced into the lymphocytes.
- (3) Gene isolated from marrow cells producing ADA is introduced into cells at embryonic stages
- (4) Lymphocytes from patient's blood are grown in culture, outside the body.

153. Identify the microorganism which is responsible for the production of an immunosuppressive molecule cyclosporin A:

- (1) *Streptococcus cerevisiae*
- (2) *Trichoderma polysporum*
- (3) *Clostridium butylicum*
- (4) *Aspergillus niger*

154. Given below are two statements:

Statement I:

Fatty acids and glycerols cannot be absorbed into the blood.

Statement II:

Specialized lymphatic capillaries called lacteals carry chylomicrons into lymphatic vessels ultimately into the blood.

In the light of the above statements, choose the appropriate answer from the options given below:

- (1) Statement I is incorrect but Statement II is correct
- (2) Both Statement I and Statement II are correct
- (3) Both Statement I and Statement II are incorrect
- (4) Statement I is correct but Statement II is incorrect

155. In which of the following animals, digestive tract has additional chambers like crop and gizzard?

- (1) *Pavo, Psittacula, Corvus*
- (2) *Corvus, Columba, Chameleo*
- (3) *Bufo, Balaenoptera, Bangarus*
- (4) *Catla, Columba, Crocodilus*

156. If '8' *Drosophila* in a laboratory population of '80' died during a week, the death rate in the population is _____ individuals per *Drosophila* per week.

- (1) zero
- (2) 0.1
- (3) 10
- (4) 1.0

157. Given below are two statements:

Statement I:

Autoimmune disorder is a condition where body defense mechanism recognizes its own cells as foreign bodies.

Statement II:

Rheumatoid arthritis is a condition where body does not attack self cells.

In the light of the above statements, choose the most appropriate answer from the options given below:

- (1) Statement I is incorrect but Statement II is correct
- (2) Both Statement I and Statement II are correct
- (3) Both Statement I and Statement II are incorrect
- (4) Statement I is correct but Statement II is incorrect

158. Which of the following functions is not performed by secretions from salivary glands?

- (1) Digestion of disaccharides
- (2) Control bacterial population in mouth
- (3) Digestion of complex carbohydrates
- (4) Lubrication of oral cavity

159. Nitrogenous waste is excreted in the form of pellet or paste by:

- (1) *Pavo*
- (2) *Ornithorhynchus*
- (3) *Salamandra*
- (4) *Hippocampus*

160. A dehydration reaction links two glucose molecules to produce maltose. If the formula for glucose is $C_6H_{12}O_6$ then what is the formula for maltose?

- (1) $C_{12}H_{24}O_{11}$
- (2) $C_{12}H_{20}O_{10}$
- (3) $C_{12}H_{24}O_{12}$
- (4) $C_{12}H_{22}O_{11}$

161. Identify the asexual reproductive structure associated with *Penicillium*: R1

- (1) Buds
- (2) Zoospores
- (3) Conidia
- (4) Gemmules

162. Given below are two statements:

Statement I:

The coagulum is formed of network of threads called thrombins.

Statement II:

Spleen is the graveyard of erythrocytes.

In the light of the above statements, choose the most appropriate answer from the options given below:

- (1) Statement I is incorrect but Statement II is correct
- (2) Both Statement I and Statement II are correct
- (3) Both Statement I and Statement II are incorrect
- (4) Statement I is correct but Statement II is incorrect

163. Detritivores breakdown detritus into smaller particles. This process is called:

- (1) Decomposition
- (2) Catabolism
- (3) Fragmentation
- (4) Humification

164. Which of the following is a correct match for disease and its symptoms?

- (1) Muscular dystrophy - An auto immune disorder causing progressive degeneration of skeletal muscle
- (2) Arthritis - Inflamed joints
- (3) Tetany - high Ca^{2+} level causing rapid spasms.
- (4) Myasthenia gravis - Genetic disorder resulting in weakening and paralysis of skeletal muscle

165. Which of the following is not the function of conducting part of respiratory system?

- (1) Provides surface for diffusion of O_2 and
- (2) It clears inhaled air from foreign particles
- (3) Inhaled air is humidified
- (4) Temperature of inhaled air is brought to temperature

166. Under normal physiological conditions in human being every 100 ml of oxygenated blood can deliver ml of O_2 to the tissues.

- (1) 10 ml
- (2) 2 ml
- (3) 5 ml
- (4) 4 ml

167. Given below are two statements: one is labelled as **Assertion (A)** and the other is labelled as **Reason (R)**.

Assertion (A):

Osteoporosis is characterised by decreased bone mass and increased chances of fractures.

Reason (R):

Common cause of osteoporosis is increased levels of estrogen.

In the light of the above statements, choose the most appropriate answer from the options given below:

- (1) (A) is not correct but (R) is correct
- (2) Both (A) and (R) are correct and (R) is the correct explanation of (A)
- (3) Both (A) and (R) are correct but (R) is not the correct explanation of (A)
- (4) (A) is correct but (R) is not correct

168. Which of the following statements with respect to Endoplasmic Reticulum is incorrect?

- (1) SER are the sites for lipid synthesis
- (2) RER has ribosomes attached to ER
- (3) SER is devoid of ribosomes
- (4) In prokaryotes only RER are present

169. Given below are two statements:

Statement I:

Restriction endonucleases recognise specific sequence to cut DNA known as palindromic nucleotide sequence. <https://www.validcollege.com>

Statement II:

Restriction endonucleases cut the DNA strand a little away from the centre of the palindromic site.

In the light of the above statements, choose the most appropriate answer from the options given below:

- (1) Statement I is incorrect but Statement II is correct
- (2) Both Statement I and Statement II are correct
- (3) Both Statement I and Statement II are incorrect
- (4) Statement I is correct but Statement II is incorrect

170. Breeding crops with higher levels of vitamins and minerals or higher proteins and healthier fats is called:

- (1) Bio-accumulation
- (2) Bio-magnification
- (3) Bio-remediation
- (4) Bio-fortification

171. If the length of a DNA molecule is 1.1 metres, what will be the approximate number of base pairs?

- (1) 6.6×10^6 bp
- (2) 3.3×10^9 bp
- (3) 6.6×10^9 bp
- (4) 3.3×10^6 bp

172. Regarding Meiosis, which of the statements is incorrect?

- (1) Four haploid cells are formed at the end of Meiosis-II
- (2) There are two stages in Meiosis, Meiosis-I and II
- (3) DNA replication occurs in S phase of Meiosis-II
- (4) Pairing of homologous chromosomes and recombination occurs in Meiosis-I

173. Natural selection where more individuals acquire specific character value other than the mean character value, leads to:

- (1) Random change
- (2) Stabilising change
- (3) Directional change
- (4) Disruptive change

174. Lippe's loop is a type of contraceptive used as:

- (1) Copper releasing IUD
- (2) Cervical barrier
- (3) Vault barrier
- (4) Non-Medicated IUD

175. Which of the following is not a connective tissue?

- (1) Neuroglia
- (2) Blood
- (3) Adipose tissue
- (4) Cartilage

176. Tegmina in cockroach, arises from:

- (1) Prothorax and Mesothorax
- (2) Prothorax
- (3) Mesothorax
- (4) Metathorax

177. In an *E. coli* strain *i* gene gets mutated and its product can not bind the inducer molecule. If growth medium is provided with lactose, what will be the outcome?

- (1) RNA polymerase will bind the promoter region
- (2) Only *z* gene will get transcribed
- (3) *z*, *y*, *a* genes will be transcribed
- (4) *z*, *y*, *a* genes will not be translated

178. Which of the following is present between the adjacent bones of the vertebral column?

- (1) Smooth muscle
- (2) Intercalated discs
- (3) Cartilage
- (4) Areolar tissue

179. Which of the following statements are true for spermatogenesis but do not hold true for Oogenesis?

- (a) It results in the formation of haploid gametes
- (b) Differentiation of gamete occurs after the completion of meiosis
- (c) Meiosis occurs continuously in a mitotically dividing stem cell population
- (d) It is controlled by the Luteinising hormone (LH) and Follicle Stimulating Hormone (FSH) secreted by the anterior pituitary
- (e) It is initiated at puberty

Choose the most appropriate answer from the options given below:

- (1) (b), (c) and (e) only
- (2) (c) and (e) only
- (3) (b) and (c) only
- (4) (b), (d) and (e) only

180. At which stage of life the oogenesis process is initiated?

- (1) Adult
- (2) Puberty
- (3) Embryonic development stage
- (4) Birth

181. Given below are two statements:

Statement I:

The release of sperms into the seminiferous tubules is called spermiation.

Statement II:

Spermiogenesis is the process of formation of sperms from spermatogonia.

In the light of the above statements, choose the most appropriate answer from the options given below:

- (1) Statement I is incorrect but Statement II is correct
- (2) Both Statement I and Statement II are correct
- (3) Both Statement I and Statement II are incorrect
- (4) Statement I is correct but Statement II is incorrect

182.

Given below are two statements: one is labelled as Assertion (A) and the other is labelled as Reason (R).

Assertion (A):

All vertebrates are chordates but all chordates are not vertebrates.

Reason (R):

Notochord is replaced by vertebral column in the adult vertebrates.

In the light of the above statements, choose the most appropriate answer from the options given below:

- (1) (A) is not correct but (R) is correct
- (2) Both (A) and (R) are correct and (R) is the correct explanation of (A)
- (3) Both (A) and (R) are correct but (R) is not the correct explanation of (A)
- (4) (A) is correct but (R) is not correct

183.

In-situ conservation refers to:

- (1) Conserve only extinct species
- (2) Protect and conserve the whole ecosystem
- (3) Conserve only high risk species
- (4) Conserve only endangered species

184.

Select the incorrect statement with reference to mitosis:

- (1) Splitting of centromere occurs at anaphase.
- (2) All the chromosomes lie at the equator at metaphase.
- (3) Spindle fibres attach to centromere of chromosomes.
- (4) Chromosomes decondense at telophase.

185.

Given below are two statements:

Statement I:

Mycoplasma can pass through less than 1 micron filter size.

Statement II:

Mycoplasma are bacteria with cell wall

In the light of the above statements, choose the most appropriate answer from the options given below:

- (1) Statement I is incorrect but Statement II is correct
- (2) Both Statement I and Statement II are correct
- (3) Both Statement I and Statement II are incorrect
- (4) Statement I is correct but Statement II is incorrect

Section - B (Biology : Zoology)

186. Match List - I with List - II with respect to methods of Contraception and their respective actions.

List - I	List - II
(a) Diaphragms	(i) Inhibit ovulation and Implantation
(b) Contraceptive Pills	(ii) Increase phagocytosis of sperm within Uterus
(c) Intra Uterine Devices	(iii) Absence of Menstrual cycle and ovulation following parturition
(d) Lactational Amenorrhoea	(iv) They cover the cervix blocking the entry of sperms

Choose the correct answer from the options given below :

- (1) (a) - (iii), (b) - (ii), (c) - (i), (d) - (iv)
- (2) (a) - (iv), (b) - (i), (c) - (iii), (d) - (ii)
- (3) (a) - (iv), (b) - (i), (c) - (ii), (d) - (iii)
- (4) (a) - (ii), (b) - (iv), (c) - (i), (d) - (iii)

187. The recombination frequency between the genes a & c is 5%, b & c is 15%, b & d is 9%, a & b is 20%, c & d is 24% and a & d is 29%. What will be the sequence of these genes on a linear chromosome ?

- (1) a, c, b, d
- (2) a, d, b, c
- (3) d, b, a, c
- (4) a, b, c, d

188. Select the incorrect statement with respect to acquired immunity.

- (1) Acquired immunity is non-specific type of defense present at the time of birth.
- (2) Primary response is produced when our body encounters a pathogen for the first time.
- (3) Anamnestic response is elicited on subsequent encounters with the same pathogen.
- (4) Anamnestic response is due to memory of first encounter.

189. Select the incorrect statement regarding synapses :

- (1) Impulse transmission across a chemical synapse is always faster than that across an electrical synapse.
- (2) The membranes of presynaptic and postsynaptic neurons are in close proximity in an electrical synapse.
- (3) Electrical current can flow directly from one neuron into the other across the electrical synapse.
- (4) Chemical synapses use neurotransmitters

190. Given below are two statements :

Statement I :

In a scrubber the exhaust from the thermal plant is passed through the electric wires to charge the dust particles

Statement II :

Particulate matter (PM 2.5) can not be removed by scrubber but can be removed by an electrostatic precipitator.

In the light of the above statements, choose the most appropriate answer from the options given below :

- (1) Statement I is incorrect but Statement II is correct
- (2) Both Statement I and Statement II are correct
- (3) Both Statement I and Statement II are incorrect
- (4) Statement I is correct but Statement II is incorrect

191. Which of the following is a correct statement ?

- (1) Mycoplasma have DNA, Ribosome and cell wall
- (2) Cyanobacteria are a group of autotrophic organisms classified under Kingdom Monera.
- (3) Bacteria are exclusively heterotrophic organisms.
- (4) Slime moulds are saprophytic organisms classified under Kingdom Monera.

192. Statements related to human Insulin are given below. Which statement(s) is/are correct about genetically engineered Insulin ?

- (a) Pro-hormone insulin contain extra stretch of C-peptide
- (b) A-peptide and B-peptide chains of insulin were produced separately in *E.coli*, extracted and combined by creating disulphide bond between them.
- (c) Insulin used for treating Diabetes was extracted from Cattles and Pigs.
- (d) Pro-hormone Insulin needs to be processed for converting into a mature and functional hormone.
- (e) Some patients develop allergic reactions to the foreign insulin.

Choose the most appropriate answer from the options given below :

- (1) (c), (d) and (e) only
- (2) (a), (b) and (d) only
- (3) (b) only
- (4) (c) and (d) only

193. Which of the following statements is **not** true ?
- (1) Flippers of penguins and dolphins are a pair of homologous organs
 - (2) Analogous structures are a result of convergent evolution
 - (3) Sweet potato and potato is an example of analogy
 - (4) Homology indicates common ancestry

194. Match List - I with List - II.

List - I	List - II
(Biological Molecules)	(Biological functions)
(a) Glycogen	(i) Hormone
(b) Globulin	(ii) Biocatalyst
(c) Steroids	(iii) Antibody
(d) Thrombin	(iv) Storage product

Choose the correct answer from the options given below :

195. Which of the following are **not** the effects of Parathyroid hormone ?

- (a) Stimulates the process of bone resorption
- (b) Decreases Ca^{2+} level in blood
- (c) Reabsorption of Ca^{2+} by renal tubules
- (d) Decreases the absorption of Ca^{2+} from digested food
- (e) Increases metabolism of carbohydrates

Choose the most appropriate answer from the options given below :

- (1) (b) and (c) only
- (2) (a) and (c) only
- (3) (b), (d) and (e) only
- (4) (a) and (e) only

196. Which one of the following statements is **correct** ?

- (1) Increased ventricular pressure causes closing of the semilunar valves.
- (2) The atrio-ventricular node (AVN) generates an action potential to stimulate atrial contraction
- (3) The tricuspid and the bicuspid valves open due to the pressure exerted by the simultaneous contraction of the atria
- (4) Blood moves freely from atrium to the ventricle during joint diastole.

197. Match List - I with List - II.

List - I	List - II
(a) Bronchioles	(i) Dense Regular Connective Tissue
(b) Goblet cell	(ii) Loose Connective Tissue
(c) Tendons	(iii) Glandular Tissue
(d) Adipose Tissue	(iv) Ciliated Epithelium

Choose the correct answer from the options given below :

- (1) (a) - (iii), (b) - (iv), (c) - (ii), (d) - (i)
- (2) (a) - (iv), (b) - (iii), (c) - (i), (d) - (ii)
- (3) (a) - (i), (b) - (ii), (c) - (iii), (d) - (iv)
- (4) (a) - (ii), (b) - (i), (c) - (iv), (d) - (iii)

198. If a colour blind female marries a man whose mother was also colour blind, what are the chances of her progeny having colour blindness ?

- (1) 100%
- (2) 25%
- (3) 50%
- (4) 75%

199. Which of the following is **not** a desirable feature of a cloning vector ?

- (1) Presence of two or more recognition sites
- (2) Presence of origin of replication
- (3) Presence of a marker gene
- (4) Presence of single restriction enzyme site

200. Ten *E. coli* cells with ^{15}N - dsDNA are incubated in medium containing ^{14}N nucleotide. After 60 minutes, how many *E. coli* cells will have DNA totally free from ^{15}N ?

- (1) 80 cells
- (2) 20 cells
- (3) 40 cells
- (4) 60 cells